

INTERNATIONAL STANDARD

IEC 61185

Second edition
2005-06

Ferrite cores (ETD-cores) intended for use in power supply applications – Dimensions



Reference number
IEC 61185:2005(E)

Publication numbering

As from 1 January 1997 all IEC publications are issued with a designation in the 60000 series. For example, IEC 34-1 is now referred to as IEC 60034-1.

Consolidated editions

The IEC is now publishing consolidated versions of its publications. For example, edition numbers 1.0, 1.1 and 1.2 refer, respectively, to the base publication, the base publication incorporating amendment 1 and the base publication incorporating amendments 1 and 2.

Further information on IEC publications

The technical content of IEC publications is kept under constant review by the IEC, thus ensuring that the content reflects current technology. Information relating to this publication, including its validity, is available in the IEC Catalogue of publications (see below) in addition to new editions, amendments and corrigenda. Information on the subjects under consideration and work in progress undertaken by the technical committee which has prepared this publication, as well as the list of publications issued, is also available from the following:

- **IEC Web Site** (www.iec.ch)

- **Catalogue of IEC publications**

The on-line catalogue on the IEC web site (www.iec.ch/searchpub) enables you to search by a variety of criteria including text searches, technical committees and date of publication. On-line information is also available on recently issued publications, withdrawn and replaced publications, as well as corrigenda.

- **IEC Just Published**

This summary of recently issued publications (www.iec.ch/online_news/justpub) is also available by email. Please contact the Customer Service Centre (see below) for further information.

- **Customer Service Centre**

If you have any questions regarding this publication or need further assistance, please contact the Customer Service Centre:

Email: custserv@iec.ch
Tel: +41 22 919 02 11
Fax: +41 22 919 03 00

INTERNATIONAL STANDARD

IEC 61185

Second edition
2005-06

Ferrite cores (ETD-cores) intended for use in power supply applications – Dimensions

© IEC 2005 — Copyright - all rights reserved

No part of this publication may be reproduced or utilized in any form or by any means, electronic or mechanical, including photocopying and microfilm, without permission in writing from the publisher.

International Electrotechnical Commission, 3, rue de Varembé, PO Box 131, CH-1211 Geneva 20, Switzerland
Telephone: +41 22 919 02 11 Telefax: +41 22 919 03 00 E-mail: inmail@iec.ch Web: www.iec.ch



Commission Electrotechnique Internationale
International Electrotechnical Commission
Международная Электротехническая Комиссия

PRICE CODE

N

For price, see current catalogue

CONTENTS

FOREWORD.....	3
1 Scope.....	5
2 Normative references	5
3 Primary standards	5
3.1 Dimensions of ETD-cores.....	5
3.2 Dimensional limits for coil formers.....	5
3.3 Pin locations and base outlines	6
3.4 Pin diameter.....	6
4 Marking.....	6
5 Mounting.....	6
Annex A (normative) Derived standards	11
Annex B (normative) Example of a standard for gauges to check the dimensions of ETD-cores meeting this primary standard	14
Figure 1 – Dimensions of ETD-cores.....	6
Figure 2 – Essential dimensions of coil formers	8
Figure 3 – Pin locations and base outlines viewed from the upper-side of the board (see 3.3).....	10
Figure A.1 – Main dimensions.....	12
Figure B.1 – Gauge dimensions	14
Table 1 – Dimensions of ETD-cores.....	7
Table 2 – Effective parameter and A_{\min} values	7
Table 3 – Essential dimensions of coil formers.....	8
Table A.1 – Main dimensions	13
Table B.1 – Gauge dimensions	14

INTERNATIONAL ELECTROTECHNICAL COMMISSION

**FERRITE CORES (ETD-CORES) INTENDED
FOR USE IN POWER SUPPLY APPLICATIONS –
DIMENSIONS**

FOREWORD

- 1) The International Electrotechnical Commission (IEC) is a worldwide organization for standardization comprising all national electrotechnical committees (IEC National Committees). The object of the IEC is to promote international co-operation on all questions concerning standardization in the electrical and electronic fields. To this end and in addition to other activities, IEC publishes International Standards, Technical Specifications, Technical Reports, Publicly Available Specifications (PAS) and Guides (hereafter referred to as "IEC Publication(s)"). Their preparation is entrusted to technical committees; any IEC National Committee interested in the subject dealt with may participate in this preparatory work. International, governmental and non-governmental organizations liaising with the IEC also participate in this preparation. IEC collaborates closely with the International Organization for Standardization (ISO) in accordance with conditions determined by agreement between the two organizations.
- 2) The formal decisions or agreements of IEC on technical matters express, as nearly as possible, an international consensus of opinion on the relevant subjects since each technical committee has representation from all interested IEC National Committees.
- 3) IEC Publications have the form of recommendations for international use and are accepted by IEC National Committees in that sense. While all reasonable efforts are made to ensure that the technical content of IEC Publications is accurate, IEC cannot be held responsible for the way in which they are used or for any misinterpretation by any end user.
- 4) In order to promote international uniformity, IEC National Committees undertake to apply IEC Publications transparently to the maximum extent possible in their national and regional publications. Any divergence between any IEC Publication and the corresponding national or regional publication shall be clearly indicated in the latter.
- 5) IEC provides no marking procedure to indicate its approval and cannot be rendered responsible for any equipment declared to be in conformity with an IEC Publication.
- 6) All users should ensure that they have the latest edition of this publication.
- 7) No liability shall attach to IEC or its directors, employees, servants or agents including individual experts and members of its technical committees and IEC National Committees for any personal injury, property damage or other damage of any nature whatsoever, whether direct or indirect, or for costs (including legal fees) and expenses arising out of the publication, use of, or reliance upon, this IEC Publication or any other IEC Publications.
- 8) Attention is drawn to the Normative references cited in this publication. Use of the referenced publications is indispensable for the correct application of this publication.
- 9) Attention is drawn to the possibility that some of the elements of this IEC publication may be the subject of patent rights. IEC shall not be held responsible for identifying any or all such patent rights.

International Standard IEC 61185 has been prepared by IEC technical committee 51: Magnetic components and ferrite materials.

This second edition cancels and replaces the first edition published in 1992 and its amendment 1 (1995).

The main changes with respect to the previous edition consist in combining it with the amendment.

The text of this standard is based on the following documents:

FDIS	Report on voting
51/818FDIS	51/826/RVD

Full information on the voting for the approval of this standard can be found in the report on voting indicated in the above table.

This publication has been drafted in accordance with the ISO/IEC Directives, Part 2.

The committee has decided that the contents of this publication will remain unchanged until the maintenance result date indicated on the IEC web site under "<http://webstore.iec.ch>" in the data related to the specific publication. At this date, the publication will be

- reconfirmed;
- withdrawn;
- replaced by a revised edition, or
- amended.

A bilingual version of this publication may be issued at a later date.

FERRITE CORES (ETD-CORES) INTENDED FOR USE IN POWER SUPPLY APPLICATIONS – DIMENSIONS

1 Scope

This International Standard specifies the dimensions that are of importance for mechanical interchangeability for ETD-cores made of ferrite, the essential dimensions of coil formers to be used with them, and the effective parameter values to be used in calculations involving them.

NOTE 1 Whilst this standard mainly applies to ferrite, its validity for iron powder cores should not be overlooked.

NOTE 2 The cores covered by this standard are designed for use in power transformers and chokes operating at high flux density and generally at frequencies higher than those feasible with EC-cores of the same material, due to a core proportioning more suitable for high-frequency applications. They are generally used in pairs.

The use of “derived” standards which give more detailed specifications of component parts whilst still permitting compliance with this standard is discussed in Annex A, which also contains an example of a derived standard for coil formers.

2 Normative references

The following referenced documents are indispensable for the application of this document. For dated references, only the edition cited applies. For undated references, the latest edition of the normative document (including any amendments) applies.

IEC 60205:2001, *Calculation of the effective parameters of magnetic piece parts*

3 Primary standards

Compliance with the following requirements ensures mechanical interchangeability of complete assemblies and coil formers.

3.1 Dimensions of ETD-cores

3.1.1 Principal dimensions

The principal dimensions of ETD-cores shall be as given in Table 1.

NOTE The dimensions of the cores may be checked by means of gauges. By way of example, a possible standard for these gauges is given in Annex B. In order to facilitate production it may be necessary to use gauges having dimensions differing from those given in Annex B, although no relaxation of the requirements for the dimensions of the cores given in Table 1 is permitted.

3.1.2 Effective parameter and A_{\min} values

The effective parameter values of a pair of cores whose dimensions comply with 3.1.1 shall be as given in Table 2.

3.2 Dimensional limits for coil formers

The essential dimensions of coil formers suitable for use with a pair of ETD-cores shall be as given in Table 3.

3.3 Pin locations and base outlines

These shall be as shown in Figure 3, in which the base is viewed in the mounting direction, i.e. from the upper side of the printed wiring board.

NOTE The module, designated as *m*, shown in the grid plan may be 2,50 mm or 2,54 mm.

3.4 Pin diameter

Coil former terminations (pins) shall be accepted by a gauge having 1,2 mm holes on true position.

4 Marking

Where a coil former is fitted with termination pins conforming to a 2,50 mm module, it shall be clearly and indelibly marked with the letter *m*, in such a position that it can readily be seen in the completed component.

5 Mounting

According to their sizes and respective weights, it is recommended that two largest cores (ETD 54 and ETD 59) be fixed on the printed board by means of screws located at two opposite sides of their coil formers.

Concerning smaller sizes such as ETD 19 and ETD 24, no mounting assemblies are defined. It is recommended that the two cores be fixed by glue or adhesive tape.

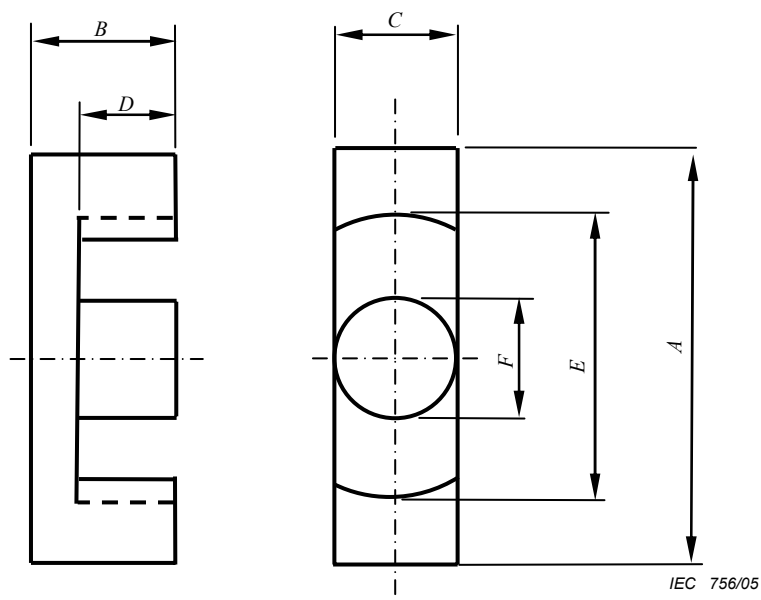

Figure 1 – Dimensions of ETD-cores

Table 1 – Dimensions of ETD-cores

Size	A mm		B mm		C mm		D mm		E mm		F mm	
	Min.	Max.	Min.	Max.	Min.	Max.	Min.	Max.	Min.	Max.	Min.	Max.
ETD 19	19,1	20,1	13,5	13,8	7,2	7,6	9,2	9,6	14,4	15,4	7,2	7,6
ETD 24	23,8	25,0	14,3	14,6	8,2	8,8	9,9	10,3	18,0	19,2	8,2	8,8
ETD 29	29,0	30,6	15,6	16,0	9,2	9,8	10,7	11,3	22,0	23,4	9,2	9,8
ETD 34	33,4	35,0	17,1	17,5	10,5	11,1	11,8	12,4	25,6	27,0	10,5	11,1
ETD 39	38,2	40,0	19,6	20,0	12,2	12,8	14,2	15,0	29,3	30,9	12,2	12,8
ETD 44	43,0	45,0	22,1	22,5	14,4	15,2	16,1	16,9	32,5	34,1	14,4	15,2
ETD 49	47,6	49,8	24,5	24,9	15,9	16,7	17,7	18,5	36,1	37,9	15,9	16,7
ETD 54	55,8	58,3	27,4	27,8	18,5	19,3	19,8	20,6	40,1	42,3	18,5	19,3
ETD 59	58,4	61,2	30,8	31,2	21,2	22,1	22,0	22,9	43,6	45,8	21,2	22,1

Table 2 – Effective parameter and A_{\min} values

Size	C_1 mm ⁻¹	C_2 mm ⁻³	l_e mm	A_e mm ²	V_e mm ³	$A_{\min}^{a)}$ mm ²
ETD 19	1,253 9	$28,412 \times 10^{-3}$	55,3	44,1	2 440	39,5
ETD 24	1,053 7	$17,811 \times 10^{-3}$	62,3	59,2	3 690	55,0
ETD 29	0,927 07	$12,139 \times 10^{-3}$	70,8	76,4	5 410	70,9
ETD 34	0,814 49	$8,387 9 \times 10^{-3}$	79,1	97,1	7 680	91,6
ETD 39	0,742 00	$5,940 1 \times 10^{-3}$	92,7	125	11 600	123
ETD 44	0,599 18	$3,462 8 \times 10^{-3}$	104	173	17 900	172
ETD 49	0,542 45	$2,569 2 \times 10^{-3}$	115	211	24 200	209
EDT 54	0,455 01	$1,625 1 \times 10^{-3}$	127	280	35 700	280
ETD 59	0,382 24	$1,038 9 \times 10^{-3}$	141	368	51 700	366

^{a)} See IEC 60205 sub-clause 2.2 for the definition of A_{\min} .

NOTE 1 The manufacturers may indicate in their catalogues more precise values than those given in Table 2.

NOTE 2 The above values have been calculated using the method given in 3.5 of IEC 60205.

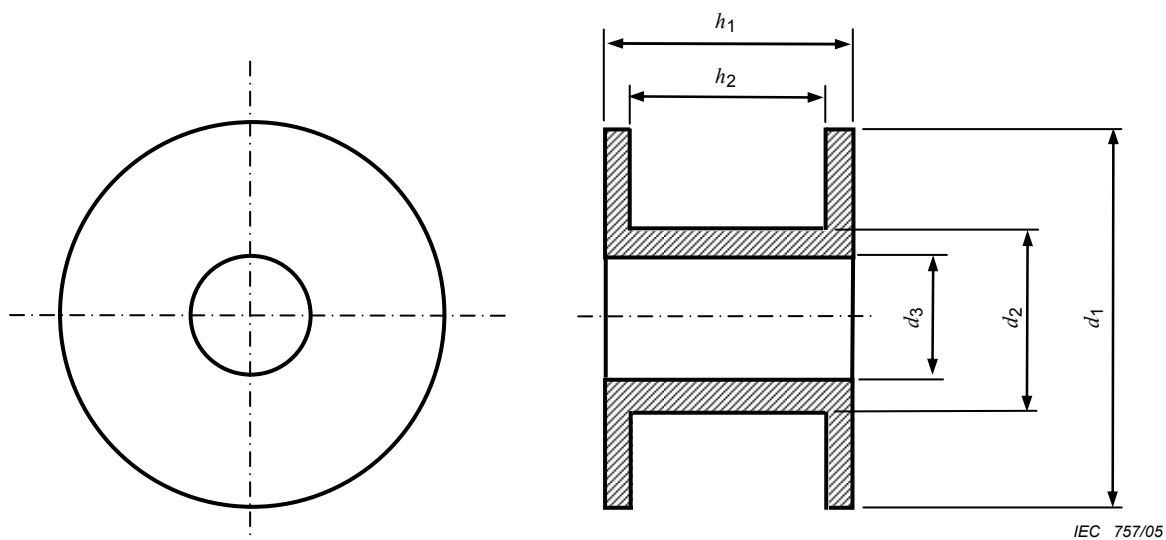
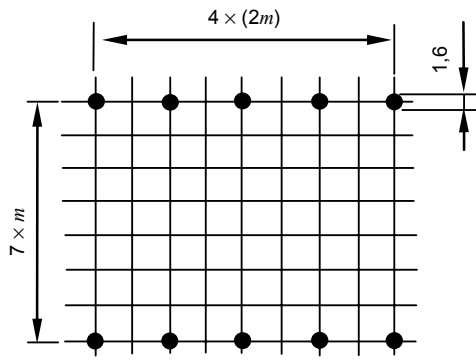

Figure 2 – Essential dimensions of coil formers

Table 3 – Essential dimensions of coil formers

Size	d_1 mm	d_2 mm	d_3 mm	h_1 mm	h_2 mm
	Max.	Max.	Min.	Max.	Min.
ETD 19	14,1	9,8	7,8	18,2	15,9
ETD 24	17,6	11,0	9,0	19,6	17,1
ETD 29	21,6	12,0	10,0	21,2	19,2
ETD 34	25,2	13,6	11,3	23,4	20,9
ETD 39	28,8	15,3	13,0	28,2	25,7
ETD 44	32,0	17,7	15,4	32,0	29,5
ETD 49	35,5	19,5	17,0	35,2	32,7
ETD 54	39,5	22,1	19,6	39,3	36,8
ETD 59	43,0	24,9	22,4	43,7	41,2



ETD 19

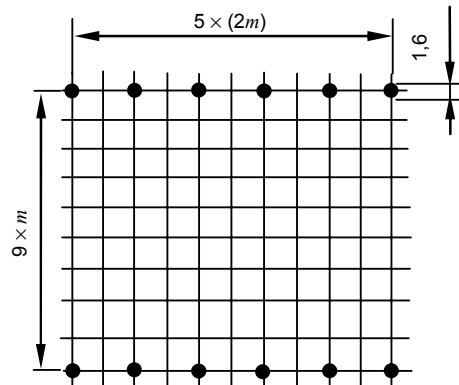

ETD 24

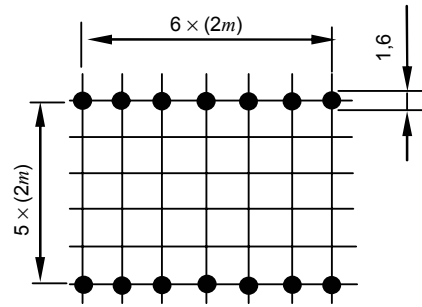

ETD 29

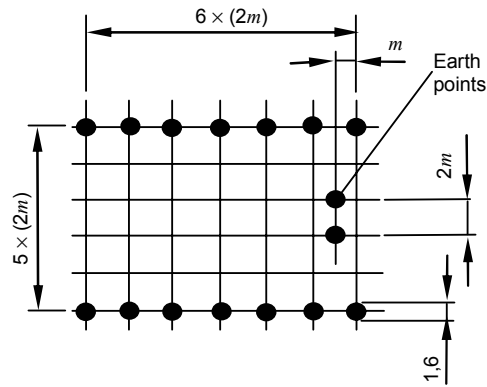

ETD 34

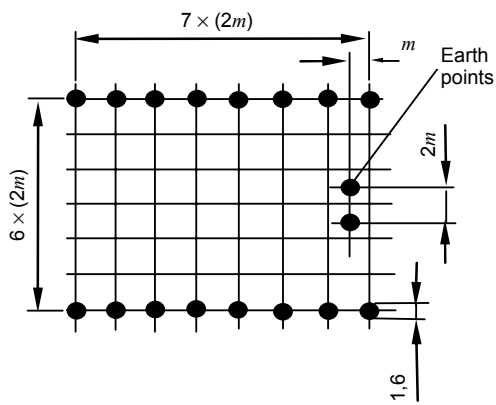

ETD 39

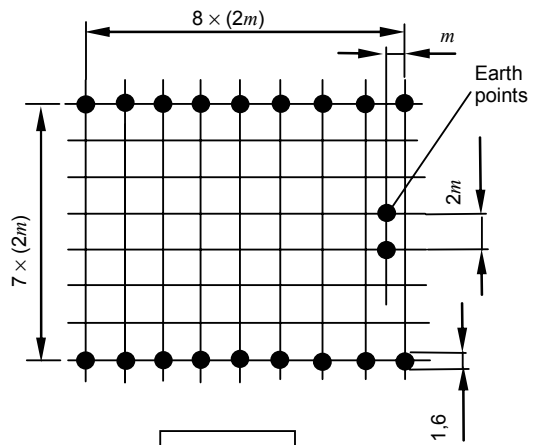

ETD 44

IEC 758/05

Figure 3 – Pin locations and base outlines viewed from the upper-side of the board (see 3.3)

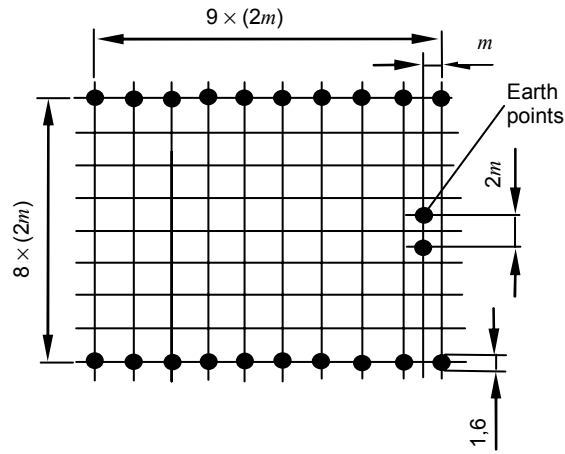

ETD 49

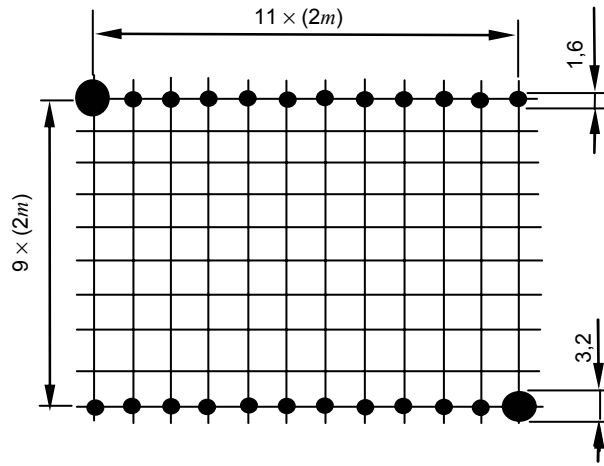

ETD 54

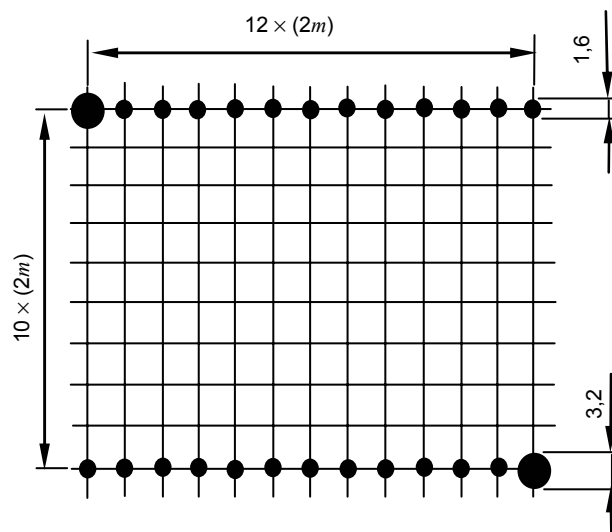

ETD 59

IEC 759/05

Figure 3 – Pin locations and base outlines viewed from the upper-side of the board (see 3.3) (continued)

Annex A (normative)

Derived standards

Clauses 1 to 4 of this primary standard establish the values for the principal dimensions of core assemblies and wound coil formers and enable full interchangeability for components complying with this primary standard to be achieved.

Parties interested in making or using ETD-cores may find it desirable to lay down local standards for everyday use, which show the dimensions and tolerances in greater detail than Clause 3 and which correspond to the state of the art in that area. These specifications are known as “derived standards”. When doing so, care should be taken not to exclude any other type of ETD-core meeting this primary standard that would also satisfy the performance specification valid for a specific case.

It should be noted that even if a component complies with a derived standard and with the requirements of Clause 3 of this primary standard, therefore permitting core assemblies and coil formers to be freely interchanged, its constituent parts may not necessarily be interchangeable.

When requirements lead to the establishment of a national standard, the relevant national standardization body is strongly requested to insert a note in such a national standard stating that:

- a) it is in accordance with the dimensional requirement of this present primary standard but that more details are given in order to promote its practical use;
- b) other solutions are possible within the framework of this primary standard and should not be excluded if the resulting core and formers are functionally interchangeable with those of the national standard.

By way of example, a possible derived standard for coil formers is given below.

An example of a standard for the main dimensions of coil formers for ETD-cores meeting this primary standard is given below.

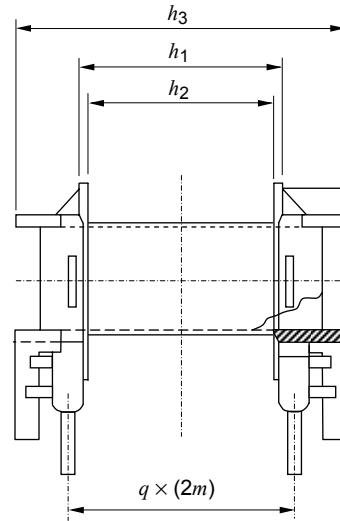
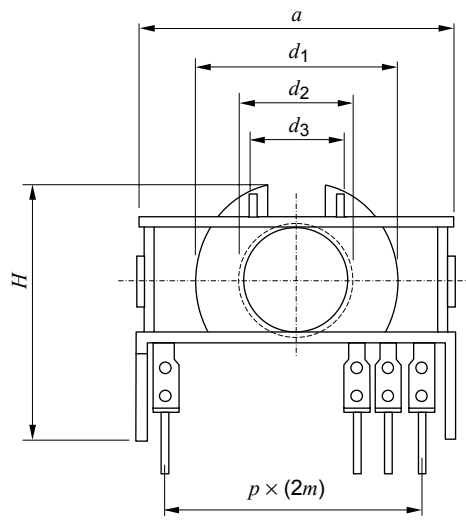

IEC 760/05

(ETD 29, ETD 34, ETD 39, ETD 44 and ETD 49)

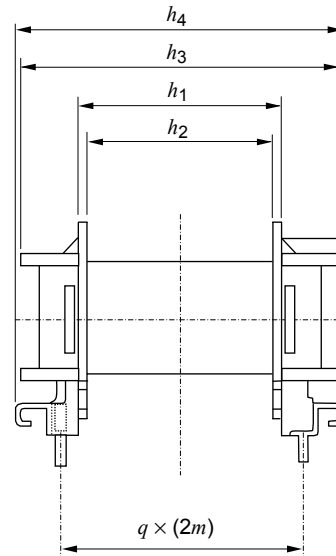
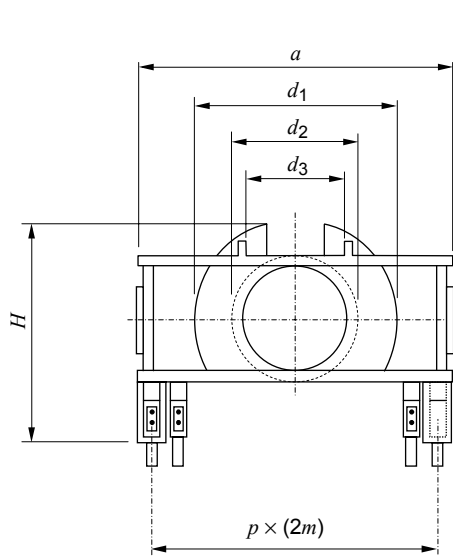

IEC 761/05

(ETD 54 and ETD 59)

Figure A.1 – Main dimensions

Table A.1 – Main dimensions

Size	<i>a</i>	<i>d</i> ₁	<i>d</i> ₂	<i>d</i> ₃	<i>h</i> ₁	<i>h</i> ₂	<i>h</i> ₃	<i>h</i> ₄	<i>H</i>	<i>p</i>	<i>q</i>
	mm	mm	mm	mm	mm	mm	mm	mm	mm		
	Max.	Max.	Max.	Min.	Max.	Min.	Max.	Max.	Max.		
ETD 29	35,3	21,6	11,8	10,0	21,2	19,2	35,2	-	25,0	6	5
ETD 34	39,6	25,2	13,4	11,4	23,4	20,9	42,8	-	34,9	6	5
ETD 39	44,6	28,9	15,1	13,1	28,2	25,7	47,8	-	37,6	7	6
ETD 44	49,6	32,0	17,5	15,5	32,0	29,5	52,5	-	40,4	8	7
ETD 49	54,5	35,7	19,0	17,0	35,2	32,7	57,5	-	42,9	9	8
ETD 54	61,5	39,4	21,6	19,6	39,3	36,2	61,4	64,0	43,0	11	9
ETD 59	66,9	42,9	24,6	22,4	43,7	40,7	66,4	69,0	46,0	12	10

.....

Annex B (normative)

Example of a standard for gauges to check the dimensions of ETD-cores meeting this primary standard

B.1 General

The gauges shall be in accordance with Table B.1 and its associated figure.

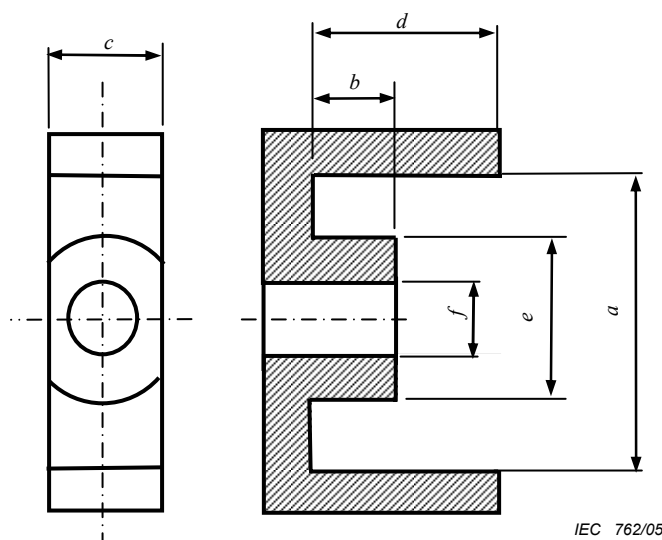

Figure B.1 – Gauge dimensions

Table B.1 – Gauge dimensions

Size	a mm		b mm		c mm	d mm	e mm		f mm	
	Min.	Max.	Min.	Max.	Min.	Min.	Min.	Max.	Min.	Max.
ETD 19	20,105	20,115	9,20	9,21	14,0	14,0	14,385	14,395	7,605	7,615
ETD 24	25,005	25,015	9,90	9,91	15,0	15,0	17,985	17,995	8,805	8,815
ETD 29	30,605	30,615	10,70	10,71	16,0	16,0	21,985	21,995	9,805	9,815
ETD 34	35,005	35,015	11,80	11,81	18,0	18,0	25,585	25,595	11,105	11,115
ETD 39	40,005	40,015	14,20	14,21	20,0	20,0	29,285	29,295	12,805	12,815
ETD 44	45,005	45,015	16,10	16,11	25,0	23,0	32,485	32,495	15,205	15,215
ETD 49	49,805	49,815	17,70	17,71	28,0	25,0	36,085	36,095	16,705	16,715
ETD 54	55,805	55,815	19,80	19,81	28,0	28,0	40,085	40,095	19,305	19,315
ETD 59	61,205	61,215	22,00	22,01	32,0	32,0	43,585	43,595	22,105	22,115

B.2 Procedure and requirements

To check the winding space, the gauge shall be fully inserted into the core without forcing; when fully inserted, the gauge shall meet the mating surface of the outer legs of the core under test.



Standards Survey

The IEC would like to offer you the best quality standards possible. To make sure that we continue to meet your needs, your feedback is essential. Would you please take a minute to answer the questions overleaf and fax them to us at +41 22 919 03 00 or mail them to the address below. Thank you!

Customer Service Centre (CSC)

International Electrotechnical Commission

3, rue de Varembé
1211 Genève 20
Switzerland

or

Fax to: **IEC/CSC** at +41 22 919 03 00

Thank you for your contribution to the standards-making process.

A Prioritaire

Nicht frankieren
Ne pas affranchir



Non affrancare
No stamp required

RÉPONSE PAYÉE

SUISSE

Customer Service Centre (CSC)
International Electrotechnical Commission
3, rue de Varembé
1211 GENEVA 20
Switzerland



Q1 Please report on **ONE STANDARD** and **ONE STANDARD ONLY**. Enter the exact number of the standard: (e.g. 60601-1-1)

.....

Q2 Please tell us in what capacity(ies) you bought the standard (tick all that apply). I am the/a:

- purchasing agent
- librarian
- researcher
- design engineer
- safety engineer
- testing engineer
- marketing specialist
- other.....

Q3 I work for/in/as a: (tick all that apply)

- manufacturing
- consultant
- government
- test/certification facility
- public utility
- education
- military
- other.....

Q4 This standard will be used for: (tick all that apply)

- general reference
- product research
- product design/development
- specifications
- tenders
- quality assessment
- certification
- technical documentation
- thesis
- manufacturing
- other.....

Q5 This standard meets my needs: (tick one)

- not at all
- nearly
- fairly well
- exactly

Q6 If you ticked NOT AT ALL in Question 5 the reason is: (tick all that apply)

- standard is out of date
- standard is incomplete
- standard is too academic
- standard is too superficial
- title is misleading
- I made the wrong choice
- other

Q7 Please assess the standard in the following categories, using the numbers:

- (1) unacceptable,
- (2) below average,
- (3) average,
- (4) above average,
- (5) exceptional,
- (6) not applicable

- timeliness.....
- quality of writing.....
- technical contents.....
- logic of arrangement of contents
- tables, charts, graphs, figures.....
- other

Q8 I read/use the: (tick one)

- French text only
- English text only
- both English and French texts

Q9 Please share any comment on any aspect of the IEC that you would like us to know:

.....

.....

.....

.....

.....

.....

.....

.....

.....

.....

.....



.....

ISBN 2-8318-7998-1



9 782831 879987

ICS 29.100.10

Typeset and printed by the IEC Central Office
GENEVA, SWITZERLAND