

INTERNATIONAL STANDARD

IEC
62273-1

First edition
2007-02

Methods of measurement for radio transmitters –

Part 1: Performance characteristics of terrestrial digital television transmitters



Reference number
IEC 62273-1:2007(E)

Publication numbering

As from 1 January 1997 all IEC publications are issued with a designation in the 60000 series. For example, IEC 34-1 is now referred to as IEC 60034-1.

Consolidated editions

The IEC is now publishing consolidated versions of its publications. For example, edition numbers 1.0, 1.1 and 1.2 refer, respectively, to the base publication, the base publication incorporating amendment 1 and the base publication incorporating amendments 1 and 2.

Further information on IEC publications

The technical content of IEC publications is kept under constant review by the IEC, thus ensuring that the content reflects current technology. Information relating to this publication, including its validity, is available in the IEC Catalogue of publications (see below) in addition to new editions, amendments and corrigenda. Information on the subjects under consideration and work in progress undertaken by the technical committee which has prepared this publication, as well as the list of publications issued, is also available from the following:

- **IEC Web Site (www.iec.ch)**
- **Catalogue of IEC publications**
The on-line catalogue on the IEC web site (www.iec.ch/searchpub) enables you to search by a variety of criteria including text searches, technical committees and date of publication. On-line information is also available on recently issued publications, withdrawn and replaced publications, as well as corrigenda.
- **IEC Just Published**
This summary of recently issued publications (www.iec.ch/online_news/justpub) is also available by email. Please contact the Customer Service Centre (see below) for further information.
- **Customer Service Centre**
If you have any questions regarding this publication or need further assistance, please contact the Customer Service Centre:

Email: custserv@iec.ch
Tel: +41 22 919 02 11
Fax: +41 22 919 03 00

www.iec.ch

INTERNATIONAL STANDARD

IEC 62273-1

First edition
2007-02

Methods of measurement for radio transmitters – Part 1: Performance characteristics of terrestrial digital television transmitters

© IEC 2007 — Copyright - all rights reserved

No part of this publication may be reproduced or utilized in any form or by any means, electronic or mechanical, including photocopying and microfilm, without permission in writing from the publisher.

International Electrotechnical Commission, 3, rue de Varembe, PO Box 131, CH-1211 Geneva 20, Switzerland
Telephone: +41 22 919 02 11 Telefax: +41 22 919 03 00 E-mail: inmail@iec.ch Web: www.iec.ch



Commission Electrotechnique Internationale
International Electrotechnical Commission
Международная Электротехническая Комиссия

PRICE CODE

W

For price, see current catalogue

CONTENTS

FOREWORD.....	4
1 Scope.....	6
2 Normative references	6
3 Terms, definitions and abbreviations	7
4 General conditions of measurement	9
4.1 Temperature and humidity.....	9
4.2 Conditions for primary power supply.....	9
4.3 Output power.....	9
4.4 Test load.....	9
4.5 Auxiliary equipment.....	9
4.6 Test equipment and test signals	10
5 General characteristics.....	10
5.1 Frequency	10
5.2 Output power.....	11
5.3 Spurious domain emission.....	14
5.4 Out-of-band domain emission.....	14
5.5 Occupied bandwidth.....	15
5.6 Power consumption.....	16
6 Transmitted signal characteristics.....	16
6.1 Intermodulation (shoulders).....	16
6.2 Modulation error ration (MER)	17
6.3 Bit error ratio (BER)	17
6.4 Equivalent noise degradation	18
6.5 Phase noise	19
7 Protection against atmospheric discharge.....	20
8 Acoustic noise	20
9 Safety.....	20
Annex A (normative) Eye-height characteristics	21
Annex B (normative) Characteristic frequency	22
Annex C (normative) Frequency drift.....	25
Annex D (normative) Attenuation of the measuring coupler.....	26
Annex E (normative) Spurious emissions/out-of-band emissions.....	28
Annex F (normative) DVB-T shoulder attenuation measurement	32
Annex G (normative) Modulation error ratio (MER) measurement.....	36
Annex H (normative) Bit error rate (BER) measurement	38
Bibliography.....	39

Figure 1 – Measuring set-up for output power	12
Figure 2 – Measuring set-up for spurious emission, out-of-band emission and bandwidth	15
Figure A.1 – Transmitter eye diagram for jitter	21
Figure B.1 – Measurement.....	23
Figure B.2 – Frequency spectrum analysis.....	24
Figure D.1 – Measurement.....	26
Figure D.2 – Relative coupling	27
Figure D.3 – Coupling attenuation.....	27
Figure E.1 – Attenuation curve.....	29
Figure E.2 – Out-of-band and spurious emissions	30
Figure E.3 – Output filter.....	30
Figure E.4 – High-frequency spectrum	31
Figure E.5 – Superimpose curve	31
Figure F.1 – Measurement	32
Figure F.2 – Shoulder attenuation	33
Figure F.3 – Analyser setting	33
Figure F.4 – Measurement system of intermodulation	34
Figure F.5 – Measurement of intermodulation at the upper side of the channel	35
Figure G.1 – Measurement	36
Figure H.1 – Measurement.....	38
Table 1 – Measurement parameters for out-of-band emission	15
Table 2 – Measurement parameters for occupied bandwidth	16
Table 3 – Equivalent noise bandwidth	18
Table A.1 – Electrical characteristic specifications for ASI link	21

INTERNATIONAL ELECTROTECHNICAL COMMISSION

METHODS OF MEASUREMENT FOR RADIO TRANSMITTERS –**Part 1: Performance characteristics of terrestrial
digital television transmitters**

FOREWORD

- 1) The International Electrotechnical Commission (IEC) is a worldwide organization for standardization comprising all national electrotechnical committees (IEC National Committees). The object of IEC is to promote international co-operation on all questions concerning standardization in the electrical and electronic fields. To this end and in addition to other activities, IEC publishes International Standards, Technical Specifications, Technical Reports, Publicly Available Specifications (PAS) and Guides (hereafter referred to as "IEC Publication(s)"). Their preparation is entrusted to technical committees; any IEC National Committee interested in the subject dealt with may participate in this preparatory work. International, governmental and non-governmental organizations liaising with the IEC also participate in this preparation. IEC collaborates closely with the International Organization for Standardization (ISO) in accordance with conditions determined by agreement between the two organizations.
- 2) The formal decisions or agreements of IEC on technical matters express, as nearly as possible, an international consensus of opinion on the relevant subjects since each technical committee has representation from all interested IEC National Committees.
- 3) IEC Publications have the form of recommendations for international use and are accepted by IEC National Committees in that sense. While all reasonable efforts are made to ensure that the technical content of IEC Publications is accurate, IEC cannot be held responsible for the way in which they are used or for any misinterpretation by any end user.
- 4) In order to promote international uniformity, IEC National Committees undertake to apply IEC Publications transparently to the maximum extent possible in their national and regional publications. Any divergence between any IEC Publication and the corresponding national or regional publication shall be clearly indicated in the latter.
- 5) IEC provides no marking procedure to indicate its approval and cannot be rendered responsible for any equipment declared to be in conformity with an IEC Publication.
- 6) All users should ensure that they have the latest edition of this publication.
- 7) No liability shall attach to IEC or its directors, employees, servants or agents including individual experts and members of its technical committees and IEC National Committees for any personal injury, property damage or other damage of any nature whatsoever, whether direct or indirect, or for costs (including legal fees) and expenses arising out of the publication, use of, or reliance upon, this IEC Publication or any other IEC Publications.
- 8) Attention is drawn to the Normative references cited in this publication. Use of the referenced publications is indispensable for the correct application of this publication.
- 9) Attention is drawn to the possibility that some of the elements of this IEC Publication may be the subject of patent rights. IEC shall not be held responsible for identifying any or all such patent rights.

International Standard IEC 62273-1 has been prepared by IEC technical committee 103: Transmitting equipment for radio communication

The text of this standard is based on the following documents:

FDIS	Report on voting
103/63/FDIS	103/65/RVD

Full information on the voting for the approval of this standard can be found in the report on voting indicated in the above table.

This publication has been drafted in accordance with the ISO/IEC Directives, Part 2.

The list of all the publications of the IEC 62273 series, under the general title *Methods of measurement for radio transmitters*, can be found on the IEC website.

The committee has decided that the contents of this publication will remain unchanged until the maintenance result date indicated on the IEC web site under "<http://webstore.iec.ch>" in the data related to the specific publication. At this date, the publication will be

- reconfirmed,
- withdrawn,
- replaced by a revised edition, or
- amended.

A bilingual edition of this document may be issued at a later date.

METHODS OF MEASUREMENT FOR RADIO TRANSMITTERS –

Part 1: Performance characteristics of terrestrial digital television transmitters

1 Scope

This part of IEC 62273 gives the conditions for measuring the performance parameters of terrestrial digital transmitters and for facilitating the comparison of measurements which are carried out by different personnel. It contains details of specially selected methods for determining the most important performance parameters of digital transmitters. The measurement methods described apply to a limited number of performance parameters, i.e. those which can give rise to ambiguous interpretation due to the use of different methods and conditions. They are neither restrictive nor mandatory: measurements can be chosen for each particular case. If necessary, additional tests can be carried out but they shall comply with those standards which have been established by other study groups, subcommittees of the IEC or other international or suitably accredited organizations.

No limits have been assigned to quantify acceptable ranges of performance parameters. These are judged to be properly included in the technical specifications for individual transmitters; however, the terms and the manner used to quantify them should ideally be those described in a future IEC publication.

The measurement methods described in this standard are intended for type approval tests. However they can equally well apply to acceptance tests measurements and quality control tests either in factories or on site.

Test signals are used to measure performance parameters for both digital and analogue terrestrial transmitters. Their electronic characteristics and their associated performance parameters are widely understood. The test signals are measured after they have gone through the transmitter equipment to determine if their degradation is within the required quality criteria.

This standard does not go into any detail regarding MPEG 2 signals or DVB processes nor does it deal with digital signal processing.

2 Normative references

The following referenced documents are indispensable for the application of this document. For dated references, only the edition cited applies. For undated references, the latest edition of the referenced document (including any amendments) applies.

IEC 60215, *Safety requirements for radio transmitting equipment*

IEC 60244-1, *Methods of measurement for radio transmitters – Part 1: General characteristics for broadcast transmitters*

ITU-R Recommendation BT.1306-3, *Error correction, data framing, modulation and emission methods for digital terrestrial television broadcasting.*

ITU-R:2004, *Radio Regulations*

ETS 30 0744, *Digital video broadcasting – Framing structure, channel coding and modulation for digital terrestrial television.*

ETSI 101 290, *Digital video broadcasting (DVB) – Measurement guidelines for DVB system*

3 Terms, definitions and abbreviations

For the purposes of this document, the following terms, definitions and abbreviations apply.

3.1

ASI

Asynchronous Serial Interface

3.2

ATSC

Advanced Television Systems Committee

3.3

BER

Bit Error Ratio

3.4

BW

Bandwidth

3.5

C/N

Ratio of the r.f. or i.f. carrier power to noise power

3.6

COFDM

Coded Orthogonal Frequency Division Multiplex

3.7

CPE

Common Phase Error

3.8

DVB

Digital Video Broadcasting

3.9

DVB-T

Digital Video Broadcasting baseline system for digital terrestrial television

3.10

END

Equivalent Noise Degradation

3.11

ETS

European Telecommunication Standard

3.12

ICI

Inter Carrier Interference

3.13

IEC

International Electrotechnical Commission

3.14

ISDB-T

Integrated Services Digital Broadcasting for Terrestrial broadcasting system

3.15

ISO

International Organization for Standardization

3.16

ITU

International Telecommunication Union

3.17

JEITA

Japan Electronics & Information Technology Industries Association

3.18

LO

Local Oscillator

3.19

MER

Modulation Error Ratio

3.20

MPEG

Moving Picture Expert Group

3.21

OFDM

Orthogonal Frequency Division Multiplex

3.22

PRBS

Pseudo Random Binary Sequence

3.23

QAM

Quadrature Amplitude Modulation

3.24

RF

Radiofrequency

3.25

RS

Reed-Solomon

3.26

SFN

Single Frequency Network

4 General conditions of measurement

4.1 Temperature and humidity

Equipment to be measured shall be operated in an environment which meets the temperature and humidity requirements as defined in their technical specifications. Temperature and humidity must never be such as to cause condensation on the equipment during measurements. In the absence of temperature and humidity requirements in the technical specifications, the provisions of IEC 60244-1 shall apply.

4.2 Conditions for primary power supply

The measurement are carried out at the nominal voltage and the nominal frequency of the power supply given in relevant equipment specification.

During a series of measurements carried out as part of one test on one equipment, the voltage and frequency of the power supply shall not deviate from the nominal values more than indicated in the relevant equipment specification.

When the nominal voltage and frequency cannot be obtained during the measurement, the following shall apply.

- a) If the quantities to be measured depend on voltage and/or frequency and the law dependence is known, the values are measured at a voltage and frequency which shall be within the limits laid down in the relevant equipment specification. If necessary, the measured quantities shall be corrected to the nominal voltage and/or frequency by calculation.
- b) If the quantities to be measured depend on voltage and/or frequency and the law of dependence is unknown, the values are measured at a voltage and frequency which shall be within 2 % of nominal voltage and 1 % of the nominal frequency, unless closer tolerances are specified in the equipment specification.

The conditions for primary power voltage and frequency shall be specified in the equipment specification. If the conditions for primary power are not specified, the provisions of IEC 60244-1, Clause 5, shall apply.

Measurements shall be carried out at the nominal voltage and the nominal frequency of the power supply given in the relevant equipment specification.

4.3 Output power

The tests shall be carried out with the transmitter set to its nominal power output after the time for stabilization, as defined in the transmitter technical specification, has elapsed. Nominal output power is taken to mean the average output power as defined by the manufacturer.

4.4 Test load

The impedance of the test load to which the transmitter is connected shall satisfy the following requirements.

The nominal value of the test load shall be the same as the line characteristic impedance for which the transmitter has been designed. The tolerances for this equality shall be the same as the load tolerances as defined in the transmitter technical specification. The test load impedance shall remain adequately constant throughout the required frequency band for test

4.5 Auxiliary equipment

If the transmitter technical specification makes reference to related auxiliary units such as pass-band filters to limit the transmitted signal frequencies or multiplexing units for multiplex transmissions, these units shall be used during the test.

4.6 Test equipment and test signals

These test procedures for digital television transmitters require that the test signals used shall conform to the digital standard implemented in the transmitter (ATSC, DVB-T, ISDB-T) and that the measuring equipment is sufficiently accurate and stable and has the necessary dynamic range to provide error-free measurements of transmitter performance parameters. However, in order to validate the physical layer of the vector r.f. signal that carrying modulating the input signal. In the case of an ASI type signal, an eye-height measurement should be taken at the signal input to the transmitter being tested. The eye-height diagram shows the I and Q time-domain base band modulating signals. Interference caused by distortions which reduce the eye height can be observed. Limits for the eye-height diagram are given in Annex A.

5 General characteristics

5.1 Frequency

5.1.1 General

In order to achieve effective use of the radiofrequency spectrum and limit mutual interference caused by radio services occupying adjacent channels, any departure from the frequency assignees to a transmitter shall be kept within strictly observed limits. These are defined by the International Telecommunication Union and are laid down in the Radio Regulations. The frequency tolerance of frequency bands are given in IEC 60244-1, Annex C. In addition to the above, for the SFN mode, each transmitter frequency shall be kept within reasonable limits to avoid the degradation caused by the frequency deviation of plural transmitters. The acceptable limits for SFN operation depends on the network configuration and transmission parameters; therefore, the acceptable limits for SFN may be specified for each system.

5.1.2 Characteristic frequency

A frequency which can easily be identified and measured in the occupied band of an emission

The term “characteristic frequency” is used in this standard to denote the actual frequency of that component of the emission, the nominal value of which is the assigned frequency.

Complementary information is given in Annex B.

5.1.3 Frequency tolerance

The frequency tolerance is the permissible departure of the characteristic frequency of an emission from the assigned frequency. The frequency tolerance is expressed in parts per 10^6 or in hertz.

5.1.4 Frequency stability

The frequency stability is the extent to which an emission maintains its assigned frequency within frequency tolerance.

A random departure from the assigned frequency is expressed as frequency error.

5.1.5 Frequency error

The frequency error is the difference between the assigned frequency and the characteristic frequency, and shall not exceed the specified frequency tolerance.

The maximum frequency error is expressed in hertz and shall be compared with the frequency tolerance in the ITU Radio Regulations or with the relevant statement in the equipment specification.

5.1.6 Frequency drift

The frequency drift of an emission is the uncontrolled continuous and irreversible variation of frequency against a predetermined time scale.

The latter shall be chosen to identify short-term and/or long-term frequency variations, expressed in hertz against a defined timescale defined in the technical specification for the equipment.

Complementary information is given in Annex C.

5.1.7 Frequency-setting error

When a transmitter is set to a particular frequency, the characteristic frequency obtained will generally differ from the assigned frequency. This is the frequency-setting error.

5.1.8 Condition of operation

The transmitter shall be operated under the conditions given in Clause 4. These conditions shall be clearly stated together with the condition of modulation.

5.1.9 Methods of measurement of the characteristic frequency of an emission

The characteristic frequency may be measured with any suitable measuring device, provided that the accuracy attained during the measurement is better than approximately 10 % of the frequency tolerance of the frequency stability given in the relevant equipment specification of the transmitter.

NOTE To achieve the required accuracy, the spectrum analyser and, if necessary, the frequency counter used should be synchronized with a frequency reference independent of the transmitter being tested (GPS 10 MHz or rubidium standard).

Other methods of great precision use a standard reference frequency, the frequency of which is known with high accuracy. With such a method, the reception of a standard frequency transmission may be used to advantage.

When the frequency is to be measured as a function of time, measurements shall be made at intervals that are short enough to reveal the presence of superimposed periodic variations and long enough to reveal frequency drift. It is recommended that the measurements are made with a recording instrument.

The accuracy of the measuring method, if known, shall be stated with the results of the measurements. If not known, an estimate should be given, based on measuring data.

The conditions of operation shall also be given together with the assigned frequency of the emission which has been used as the characteristics frequency.

5.2 Output power

5.2.1 General note on output power

For a digital signal with the COFDM modulation process the power is distributed evenly throughout the transmission channel. Hence, when taking power measurements on such a signal, the total bandwidth occupied by the modulated signal shall be taken into account. The product of the mean power of the aerial voltage and current signals is defined as the power output for a particular channel.

The output power is the first parameter to be measured when checking performance parameters or carrying out conformity checks. In the case of a digital signal, the mean power value is the most appropriate for the modulation type being used

5.2.2 Measuring arrangement

Figure 1 shows the measuring set-up to be used.

5.2.3 Test signal

The transmission parameters of the test signal shall be specified for each system. If no such specification is given, a signal comprising PRBS 2²³-1-8K 64-QAM 7/8 ¼ from the COFDM encoder and modulator shall be used.

5.2.4 Method of measurement

5.2.4.1 Calorimetric method

The value for the output power is derived either by measuring the heat dissipated in the test load or from a bolometer reading of the r.f. signal derived from a calibrated directive coupler on the transmitter output line. The output power is expressed in watts.

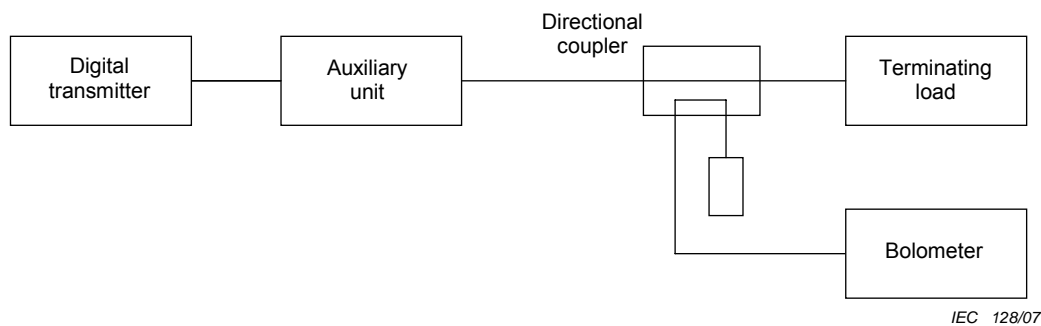

Figure 1 – Measuring set-up for output power

When the temperature rise of the water in the test load is used to derive the output power value, the following two sets of readings are taken so as to minimize the thermometer errors.

- a) Thermometer A: water temperature at load inlet; Thermometer B: water temperature at load outlet
- b) Thermometer B: water temperature at load inlet; Thermometer A: water temperature at load outlet

Inlet and outlet temperatures are taken as the averages of the two readings in each case.

The output power value is derived from the following formula:

$$P(W) = 0,069D \cdot \Delta\theta$$

where

$P(W)$ is the measured power;

D is the water flow rate in litres per minute;

$\Delta\theta$: is the difference between the load inlet and the outlet water temperatures in °C.

This formula only applies in the absence of additives to the water.

When a bolometer reading of the r.f. signal from a calibrated directional coupler is used to derive the output power value, the following formula is used:

$$P(W) = (10^{ATT/10}) \times (P_m) \times (\text{cal factor})$$

where

$P(W)$ is the measured power;

$ATT(\text{dB})$ is the attenuation of the directional coupler;

cal factor(%) is the calibration factor for the bolometer probe at the operating frequency.

The method of calibration of the directional coupler is given in Annex D.

Since the output power value is a fundamental reference point when quantifying non-linear distortion parameters, it is recommended that a permanent output power reading is displayed by a measuring instrument capable of measuring the r.f. signal from the directional coupler which is bridged across the output r.f. line. This reading shall be available throughout the validation of the transmitter performance parameters.

5.2.4.2 Spectrum analyser method

- a) Set the modulator output to reference signal
- b) Connect a spectrum analyser to the measurement point, using a cable the loss of which has been calibrated. If the power level at the measurement point is too high, adjust it in such a way that it falls within the measurement range of the spectrum analyser, using a calibrated directional coupler and attenuator.
- c) Setting of the spectrum analyser

Centre frequency	Span	RBW	VBW	Detect mode	Channel BW
Centre frequency of the modulated wave	10 MHz	30 kHz	300 kHz	Sample detection	See note
NOTE The channel bandwidth is defined for each system. Use the channel power measurement to measure the power.					

- d) Determine the power from the reading of the spectrum analyser and the calibration value.

Power (dBm) = Spectrum analyser reading (dBm) + cable loss (dB) + calibration value (dB) + directional coupler coupling factor (dB) + attenuator value

$$P(W) = 10^{P(\text{dBm})/10}/1000$$

5.3 Spurious domain emission

5.3.1 Definition

Spurious emission is an emission on a frequency or frequencies which are outside the necessary bandwidth and the level of which may be reduced without affecting the corresponding transmission of information. Spurious emissions include harmonic emissions, parasitic emissions, intermodulation products, frequency conversion products, and single sideband phase noise, but exclude out-of-band emissions (Article 1, No. 1.145 of the ITU Radio Regulations).

The reference bandwidth is the bandwidth in which the spurious emission level is specified.

5.3.2 Method of measurement

Measurements are taken using the set-up shown in Figure 2. The directive coupler which bridges the output transmission line shall have an appropriate directivity; also, its frequency response (with a fall-off of 6 dB per octave) shall be taken into account when taking measurements. A spectrum analyser having a dynamic range of at least 70 dB and with a resolution bandwidth between 1 kHz and 1 MHz shall be used. The dynamic range of the measurement should be extended by the use of appropriate filters. The transmission parameter of the test signal shall be specified for each system. If no such specification is given, a signal comprising PRBS 2²³-1 8K 64-QAM 7/8 ¼ from the COFDM encoder and modulator is used.

The limits are absolute value or attenuation compared to the average output power supplied by the transmitter; at nominal power the harmonic level shall be measured at the same resolution bandwidth.

The values shall be expressed in W/dBm or dB.

Complementary information is given in Annex E.

5.4 Out-of-band domain emission

5.4.1 Definition

Out-of-band emission is an emission on a frequency or frequencies immediately outside the necessary bandwidth which results from the modulation process, but excluding spurious emissions (Article 1, No. 1.144 of the ITU Radio Regulations). The boundary between the out-of-band and spurious domain occurs at a separation of $\pm 250\%$ of necessary bandwidth.

The value of the out-of-band emission shall be defined for critical and non-critical mask.

5.4.2 Method of measurement

Measurements are taken using the set-up shown in Figure 2. The transmission parameter set of test signal shall be specified for each system, but, unless specified, PRBS 2²³-1 8K 64-QAM 7/8 ¼ from the COFDM encoder and modulator is used.

Power values of out-of-band signals are measured with an r.f. spectrum analyser whose resolution is specified for each system, but, unless specified, the parameter sets shown in Table 1 shall apply. The frequencies at which power values are measured are chosen in relation to the central channel frequency. The results are given in a table or as a graph in which relative values in dB are given for frequencies that are related to the centre channel frequency

Table 1 – Measurement parameters for out-of-band emission

Centre frequency	Sweep range (span)	Resolution bandwidth (RBW)	Filter passband (VBW)	Detect mode	Note
Centre frequency of the r.f. signal	500 % of the necessary bandwidth	4 kHz	4 kHz	Positive peak detection	Standard for DVB-T system
Centre frequency of the r.f. signal	500 % of the necessary bandwidth	10 kHz	300 Hz or lower	Positive peak detection	Standard for ISDB-T system

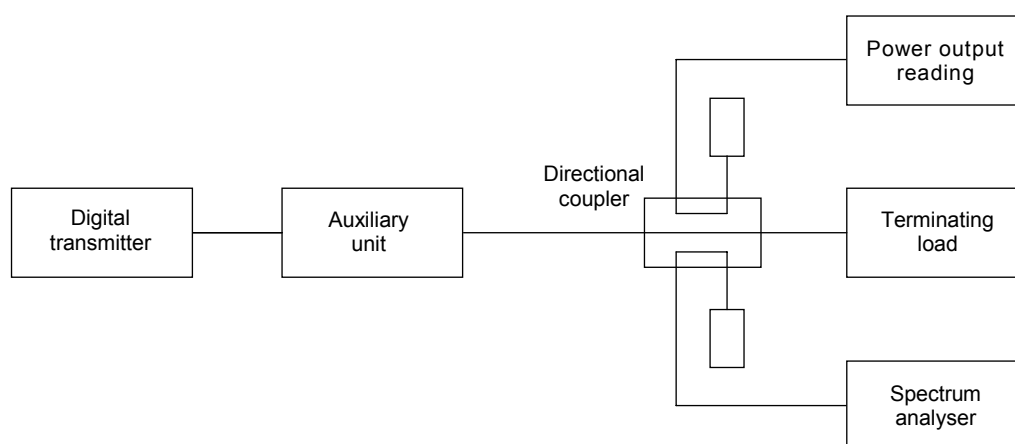

IEC 129/07

Figure 2 – Measuring set-up for spurious emission, out-of-band emission and bandwidth

5.5 Occupied bandwidth

5.5.1 Definition

The width of a frequency band is such that, below the lower and above the upper, frequency limits the mean powers emitted are each equal to a specified percentage $\beta/2$ of the total mean power of a given emission.

Unless otherwise specified in an ITU-R Recommendation for the appropriate class of emission the value of $\beta/2$ should be taken as 0,5 % (Article 1, No. 153 of the ITU Radio Regulations)

5.5.2 Method of measurement

Measurements are taken using the set-up shown in Figure 2. The transmission parameter set of test signal shall be specified for each system, but, unless specified, PRBS 2²³-1 8K 64-QAM 7/8 ¼ from the COFDM encoder and modulator is used.

Power values of signals are measured with an r.f. spectrum analyser whose resolution is specified for each system, but unless specified, the parameter sets are shown in Table 2.

The bandwidth should be determined containing 99 % of the energy of COFDM signal from the spectrum measured by the spectrum analyser.

Table 2 – Measurement parameters for occupied bandwidth

Centre frequency	Sweep range (span)	Resolution bandwidth (RBW)	Filter passband (VBW)	Detect mode	Note
Centre frequency of the r.f. signal	20 MHz	4 kHz	4 kHz	Positive peak detection	Standard for DVB-T system
Centre frequency of the r.f. signal	20 MHz	10 kHz	300 Hz or lower	Positive peak detection	Standard for ISDB-T system

Complementary information is given in Annex E.

5.6 Power consumption

This parameter is measured in conformity with 5.4 of IEC 60244-1. The transmission parameter set of test signals shall be specified for each system, but, unless specified, PRBS 2²³-1 8K 64-QAM 7/8 ¼ from the COFDM encoder and modulator is used.

6 Transmitted signal characteristics

6.1 Intermodulation (shoulders)

6.1.1 Definition

For the multi-carrier transmission system such as COFDM, intermodulation distortion mainly caused by transmitter non-linearity may affect the critical degradation to the COFDM signal.

Intermodulation distortion is composed of unwanted spectral energy both in-band and out-of-band. The in-band energy will cause the degradation of the transmitted signal and the out-of-band energy will cause adjacent channel interference.

The quantity of intermodulation distortion products may be measured as the out-of-band emission of the transmitter. This out-of band emission is named “shoulder attenuation”.

NOTE Out-of-band emission caused by the transmitter may be decreased by an output filter. Therefore, shoulder attenuation should be measured without an output filter.

6.1.2 Methods of measurement

Measurements are taken using the set-up shown in Figure 2. The transmission parameter set of test signals shall be specified for each system, but, unless specified, PRBS 2²³-1 8K 64-QAM 7/8 ¼ from the COFDM encoder and modulator is used.

Power values of out-of-band signals are measured with an r.f. spectrum analyser whose resolution is specified for each system, but, unless specified, the parameter sets shown in Table 1 shall apply. The frequencies at which power values are measured are chosen in relation to the centre channel frequency. The difference of maximum value of the in-band spectrum and the measured value of the out-of-band spectrum is defined as a “shoulder attenuation”. The frequencies of out-of-band emission for measurement shall be specified for each system.

Complementary information is given in Annex F.

6.2 Modulation error ratio (MER)

6.2.1 Definition

This parameter is a measure of the total degradation in the transmitted signal due to residual carrier presence (i.e., carrier not totally suppressed) and amplitude/frequency and phase/frequency response degradations. It should be determined with the use of a receiver with the lowest possible noise factor in order to avoid causing distortion. The MER value is derived from the following formula.

<p>where <i>I</i> is the in-phase component; <i>Q</i> is the quadrature component; <i>N</i> is the number of carriers; <i>J</i> is the carrier index.</p>	$MER = 10 \lg \left\{ \frac{\sum_{j=1}^N (I_j^2 + Q_j^2)}{\sum_{j=1}^N (\delta I_j^2 + \delta Q_j^2)} \right\} \text{ dB}$
---	--

The sum of the square of the magnitudes of the ideal symbol vectors is divided by the sum of the square of the magnitudes of the symbol error vectors. The result expressed as a power ratio in dB, is defined as the modulation error ratio.

6.2.2 Method of measurement

Measurements are taken at the transmitter output using the set-up shown in Figure 2; an MER measuring unit is used instead of the spectrum analyser. The modulation parameters shall be specified for each system. If no such specification is given, measurements shall be carried out using QPSK, 16-QAM and 64-QAM signals.

Measurements shall be taken on all carriers, with an integration period to enable a sufficient number of samples to be averaged. Unless otherwise specified, 100 OFDM samples shall be averaged. The performance to be achieved will be specified in the technical specification for the equipment.

Complementary information is given in Annex G.

6.3 Bit error ratio (BER)

6.3.1 Definition

The BER is the primary parameter which describes the quality of digital transmission system. This parameter is used to analyse the transmission performances and three types of error rate.

- a) The error rate according to Viterbi; this quantifies the 64QAM modulation quality.
- b) The error rate according to Reed Solomon; this quantifies the transmitter link including the interleave and inner coding effect.
- c) The error rate according to Reed Solomon; this quantifies the quality of the total transmitter chain.

6.3.2 Method of measurement

The measurement set-up is as shown Figure 2 except that the spectrum analyser is replaced by a BER measuring unit.

The test signal is taken from a PRBS generator with a period of $2^{23}-1$.

The modes used are 8K 64-QAM 7/8 1/4 and 2K 64-QAM 7/8 1/4 since these are the least robust and the most sensitive to internally generated transmitter noise.

It is recommended that a PRBS 2²³-1 sequence is used in order to assure correct bit interleaving. The duration of test should be sufficient to assure the reliability of the BER of the measuring result.

A minimum of 100 samples is requested for the test.

Complementary information is given in Annex H.

6.4 Equivalent noise degradation

6.4.1 Definition

The equivalent noise degradation (END) is the implementation loss caused by a digital TV transmitter in term of added noise in the r.f. transmission channel compared to the noise theoretical figure. This important measure represents the full performance of a digital TV transmitter regarding to the sum of the degradation due to the phase noise and the shoulders performances.

The equivalent noise bandwidths of each system are shown in Table 3.

Table 3 – Equivalent noise bandwidth

System ^a	F_{Spacing} kHz	Number of carrier	Equivalent Noise bandwidth(MHz)	Remarks
DVB-T 8K(8 MHz)	1,11607	6816	7,60714	
DVB-T 2k(8 MHz)	4,46428	1704	7,60714	
DVB-T 8K(7 MHz)	0,97658	6816	6,65625	
DVB-T 2k(7 MHz)	3,90625	1704	6,65625	
DVB-T 8K(6 MHz)	0,83705	6816	5,70535	
DVB-T 2k(6 MHz)	3,34821	1704	5,70535	
ISDB-T 8k(6 MHz)	0,99206(=125/126)	5617	5,57242	
ISDB-T 4k(6 MHz)	1,98412(=125/63)	2809	5,57341	
ISDB-T 2k(6 MHz)	3,96825(=250/63)	1405	5,57539	
ISDB-T 8k(7 MHz)	1,15740(=125/108)	5617	6,50115	
ISDB-T 4k(7 MHz)	2,31481(=125/54)	2809	6,50231	
ISDB-T 2k(7 MHz)	4,62962(=125/27)	1405	6,50462	
ISDB-T 8k(8 MHz)	1,32275(=250/189)	5617	7,42984	
ISDB-T 4k(8 MHz)	2,64550(=500/189)	2809	7,43121	
ISDB-T 2k(8 MHz)	5,29100(=1000/189)	1405	7,43386	

^a All the systems described in Table 3 are taken from ITU-R Recommendation BT.1306.

6.4.2 Method of measurement

For each specific modulation scheme, the END is obtained from the difference in dB of the C/N ratio needed to reach a BER of 2×10^{-4} before RS (outer) decoding and the C/N ratio that would theoretically give a BER of 2×10^{-4} for a Gaussian channel (Annex A of ETS 300 744).

The measurement set-up is as in Figure 2 except that the spectrum analyser is replaced by a BER measuring unit.

6.5 Phase noise

6.5.1 Definition

Phase noise at any conversion frequency can occur in a transmitter due to instability of the local oscillators (LO). In the COFDM modulation process, phase noise can cause an overall phase error which affects all carriers at the same time.

Phase noise causes both common phase error (CPE) and inter carrier interference (ICI). These reduce the transmitter noise margin and increase the BER.

NOTE This type of phase noise causes circular shift to constellation points in the I and Q plane.

6.5.2 Method of measurement.

The measurement is made at the local oscillator output or at a test point where this carrier is present. Either a spectrum analyser or a noise measuring set is used. If the particular noise measuring set measures the noise on both sides of the carrier, the reading obtained shall be reduced by 3 dB.

For information, the typical average level of single sideband phase noise in an external (standard frequency transmission or GPS) 10 MHz reference signal is as follows. The performance to be achieved will be specified at the above frequency offsets in the technical specification for the equipment.

Offset from carrier	Level
10 Hz	- 90 dBc/Hz
100 Hz	- 100 dBc/Hz
1 kHz	- 110 dBc/Hz
10 kHz	- 120 dBc/Hz
100 kHz	- 130 dBc/Hz
1 MHz	- 140 dBc/Hz

For information typical average levels of single-sideband phase noise in the external local oscillator signal are given as follows.

Offset from carrier	Level
10 Hz	- 65 dBc/Hz
100 Hz	- 85 dBc/Hz
1 kHz	- 85 dBc/Hz
10 kHz	- 95 dBc/Hz
100 kHz	- 113 dBc/Hz
1 MHz	- 130 dBc/Hz

7 Protection against atmospheric discharge

These measurements do not differ in any way from the measurements which are carried out on analogue broadcasting equipment and hence they are made in conformity with IEC 60244-1.

These measurements form part of the qualification phase of the manufacturing documentation and hence are not specified as being part of factory and on-site tests

8 Acoustic noise

These measurements do not differ in any way from the measurements which are carried out on analogue broadcasting equipment and hence they are made in conformity with IEC 60244-1.

These measurements form part of the qualification phase of the manufacturing documentation and hence are not specified as being part of factory and on-site tests

9 Safety

These measurements do not differ in any way from the measurements which are carried out on analogue broadcasting equipment and hence they are made in conformity with IEC 60215.

Annex A (normative)

Eye-height characteristics

The eye-height characteristics are given in Table A.1 and Figure A.1.

Table A.1 – Electrical characteristic specifications for ASI link

Transmitter output characteristics	Units	
Output voltage (p-p)	mV	800 ± 10 %
Deterministic jitter (DJ) (p-p)	%	10
Random jitter (RJ) (p-p)	%	8
Return loss	dB	Under consideration
Max. rise/fall time (20-80 %)	ns	1,2

Receiver input characteristics	Units	
Min. sensitivity (D21,5 idle pattern)	mV	200
Max. input voltage (p-p)	mV	880
s_{11} (range: 0, 1 to 1,0 × bit rate)	dB	–17
Min. discrete connector return loss (0,3 MHz – 1 GHz)	dB	15

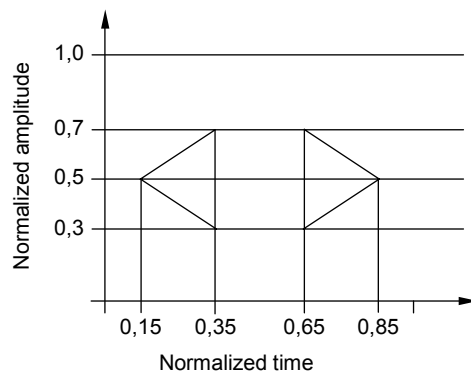
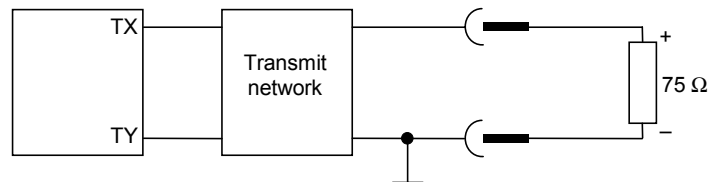

IEC 130/07

Figure A.1 – Transmitter eye diagram for jitter

Annex B (normative)

Characteristic frequency

B.1 Description of the test/measurement

The frequency accuracy of the transmitter shall be ascertained. The mode (2 k, 4 k or 8 k) and the operating mode (MFN or SFN) shall be taken into account for the tolerances.

B.2 Measuring units

The following measuring units are required.

- Transport stream generator (if a PRBS mode is not available on the modulator).
- SFN adapter (optional).
- Spectrum analyser.
- Frequency counter (optional).

B.3 Measurement

It is preferable to determine the frequency by measuring pilots in the OFDM spectrum. The measurement can be taken at the exciter (r.f. measuring point) (see Figure B.1).

If an oscillator measuring point that has a convertible ratio to the mean output frequency is available, a measurement can also be taken here with a frequency counter or spectrum analyser. The frequency offset stated in the operating manual for converting the oscillator frequency to the mean channel frequency should be checked.

If an individual centre carrier (CW-mode) can be switched on at the modulator/transmitter, it is also possible to measure this with a frequency counter or a spectrum analyser. Operation in CW-mode shall be allowed for the transmitter. If there is any doubt about this, the power amplifier stage shall be switched off or muted and a measurement point at the exciter shall be available.

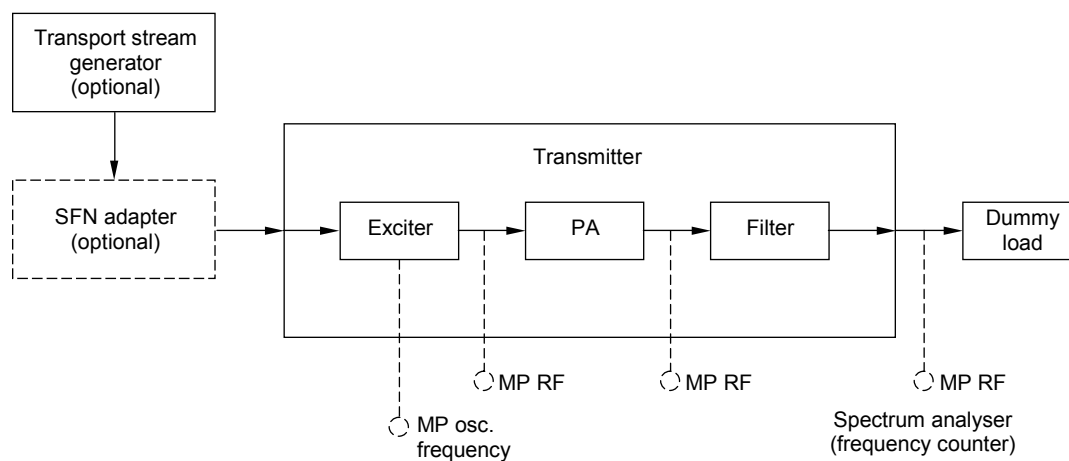

IEC 131/07

Figure B.1 – Measurement

Measurement in the COFDM frequency spectrum is only possible on the continual pilots. These are transmitted with approximately 30 % greater amplitude compared with the useful carrier. Due to the added guard interval, however, all pilots are not orthogonal in the case of all guard interval lengths, a fact that also differs between 2 k and 8 k mode.

In the case of DVB-T 8 k mode, the pilot of the mean frequency can be used for the measurement for all guard interval settings in the case of carrier No. 3408.

a) Example for VHF

- For Channel 8 (7 MHz channel, Standard G, centre frequency 198,5 MHz), it shall be possible to find the pilot at 198'500'000 Hz.

b) Example for UHF

- For Channel 40 (8 MHz channel, Standard B, centre frequency 626 MHz), it shall be possible to find the pilot at 626'000'000 Hz.
- For Channel 50 (6 MHz channel, Standard M, centre frequency 689 MHz), it shall be possible to find the pilot at 689'000'000 Hz.

In the case of DVB-T 2 k mode, only the pilot for carrier No. 1140 can be measured for all guard interval settings.

In the case of 8 MHz channels, this is 1'285'714 Hz (exactly 1'285'714,3 Hz), in the case of 7 MHz channels 1'125'000 Hz and in the case of 6 MHz channels this is 964'285,7 Hz above the mean channel frequency.

c) Example for VHF

- For Channel 8 (7 MHz channel, Standard G, centre frequency 198,5 MHz), it shall be possible to find the pilot at 199'625'000 Hz.

d) Example for UHF

- For Channel 40 (8 MHz channel, Standard B, centre frequency 626 MHz), it shall be possible to find the pilot at 627'285'714 Hz.
- For Channel 50 (6 MHz channel, Standard M, centre frequency 689 MHz), it shall be possible to find the pilot at 689'964'286 Hz.

The following settings shall be made on the spectrum analyzer (see Figure B.2).

- Synchronize the analyser with an external reference, for example, 10 MHz of GPS receiver.
- Centre frequency: to mean channel frequency being measured, span 100 Hz, resolution bandwidth: 1 Hz (if necessary filter type – FFT mode).

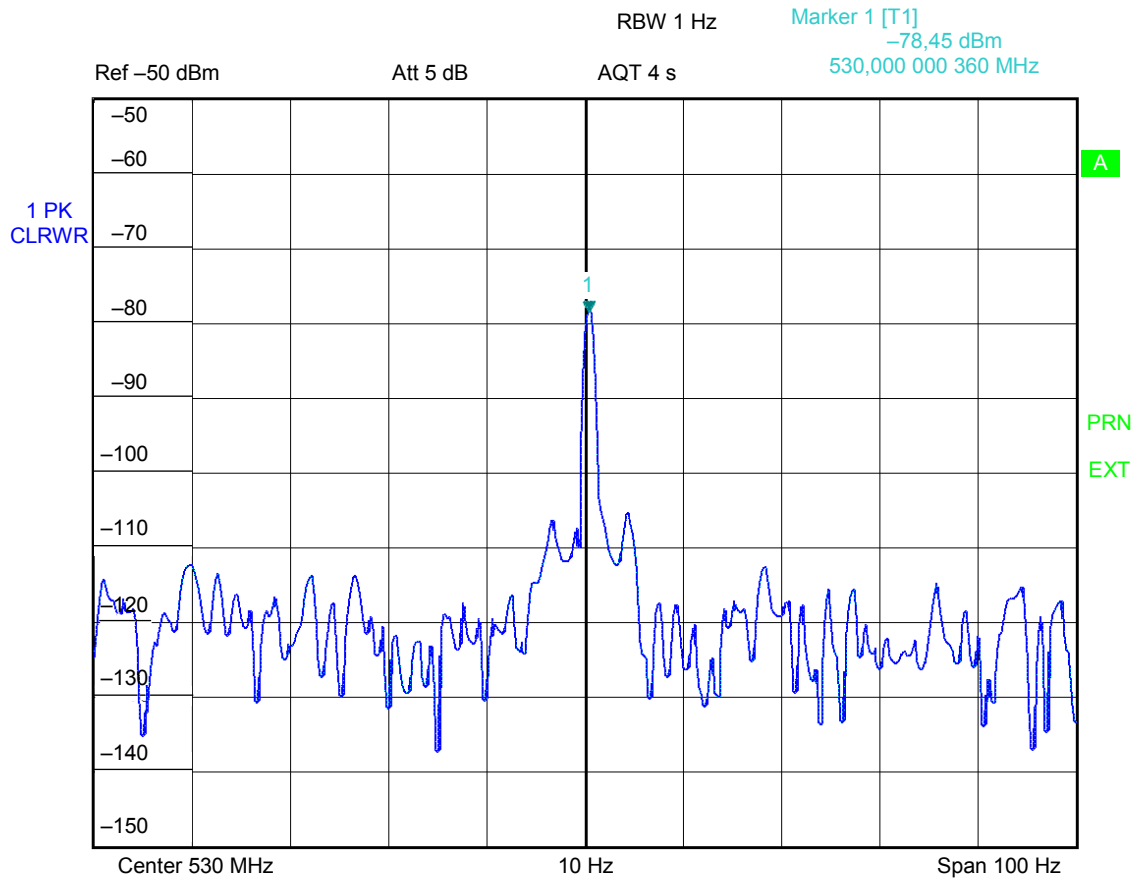

Date: 2.JUL.2002 10:50:16

IEC 132/07

Figure B.2 – Frequency spectrum analysis

Annex C (normative)

Frequency drift

C.1 Description of the test/measurement

The frequency stability of the transmitter shall be determined.

C.2 Measuring units

The following measuring units are required.

- Transport stream generator (if a PRBS mode is not available on the modulator).
- SFN adapter (optional).
- Spectrum analyser.
- Frequency counter (optional).

C.3 Measurement

When taking the measurements, it shall be ensured that the pilots are stable (no slow fluctuation or jitter). One or different pilots can be observed with the frequency analyser with the aid of the “max hold” function; therefore, attention shall at least be paid to the pilot used in the frequency measurement described above.

Jitter will be immediately noticeable.

In order to make a statement about long-term stability, the measurement shall be carried out for a period of at least 24 h, for example, with “max hold” on the frequency analyser. If the transmitter is working correctly, there should be no visible drift during this period, because even in MFN mode with an accuracy of 10^{-7} per year, only deviations of tenths of one hertz per day are expected.

Measurement of the short-term stability with the frequency analyser shall always be performed in order to recognize problems in the r.f. spectrum.

If the measurement of the long-term stability is carried out with the frequency counter, the frequency shall be logged periodically.

Annex D (normative)

Attenuation of the measuring coupler

D.1 Description of the test/measurement

Measuring the coupling attenuations of the measurement points for forward and return power.

A spectrum analyser with additional sweep generator or a level generator and level meter can be used to measure the coupling attenuation.

Since the demands placed on the dynamics of the display instruments is too high (0,1 dB) with the high coupling attenuations, the absolute coupling attenuation shall be determined with a step attenuator.

In all measurements, it is necessary to also take into account the attenuations of the measuring cables and adaptors.

D.2 Measuring units

The following measuring units are required.

- Spectrum analyser with additional sweep generator or level generator and level meter.

D.3 Measurement

- a) The transmitter shall be switched off and the measuring coupler released (see Figure D.1).

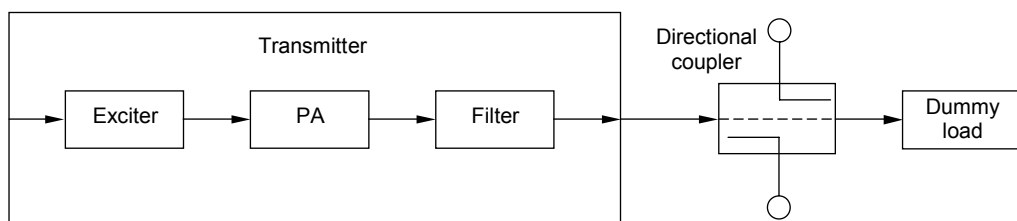

Figure D.1 – Measurement

- b) The relative coupling of the output power shall be measured (see Figure D.2).

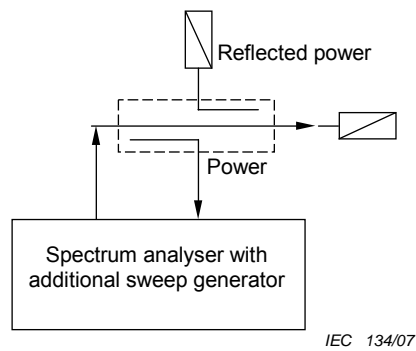

Figure D.2 – Relative coupling

- c) With a precision step attenuator, set the same value on the spectrum analyser and level meter as for measurement b). The set value is the coupling attenuation (see Figure D.3).

NOTE The attenuation of the cables and coupler should also be taken into account.

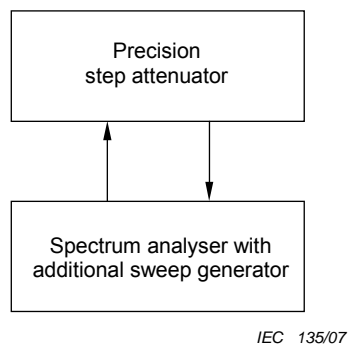

Figure D.3 – Coupling attenuation

The directivity of the coupler shall be better than 35 dB. The test-protocol of the manufacturer shall be available.

Annex E (normative)

Spurious emissions/out-of-band emissions

E.1 Description of the test/measurement

Measurement of the spurious emissions and out-of-band emissions.

E.2 Measuring units

The following measuring units are required.

- Transport stream generator (if a PRBS mode is not available on the modulator).
- SFN adapter (optional).
- Spectrum analyser with sweep generator (sweep generator function only with separate measurement – before filter and filter separate – see below).
- Channel block filter (only with special measuring method – see below).

E.3 Measurement

E.3.1 Introduction

A suitable spectrum analyser that displays a dynamic range of >90 dB at the applied digital channel power is not at present available on the market.

- One measurement possibility is to use a suitable channel block filter, but this is an expensive solution, particularly for measuring the out-of-band emissions.
- Another possibility for measuring the out-of-band emissions is to measure the filter and the digital signal before the filter separately and then to superimpose both measuring curves.

It is essential to set the pre-attenuation of the spectrum analyser “correctly”. What “correctly” means can only be determined by testing. Insufficient attenuation generates inter-modulations near to the useful signal (displayed shoulder rises), excessive attenuation increases the noise base so that no sufficient dynamic is reached.

Solution: Empirically determine the boundary between inter-modulation and noise. This is possible only with a spectrum analyser that permits manual adjustment of the pre-attenuation in 5 dB increments. 1 dB increments would be better. 10 dB increments are definitely not sufficient.

The out-of-band emissions should be measured in conformity to the parameters given in Table 1 and 5.4.3. If the frequency analyser does not offer this bandwidth, the next possible value (3 kHz or 5 kHz) shall be set. In the case of measurement with the relative level, interferer in relation to the useful signal, the ratio remains the same and no correction is required. When measuring the absolute level, a correction is required to the 4 kHz filter bandwidth.

Attention, video bandwidth: This should be approximately 10 times less than the resolution bandwidth, otherwise the measured line is smoothed and peaks are no longer displayed.

E.3.2 Description

a) Out-of-band and spurious emissions (measurement with channel block filter)

The use of a spectrum analyser with a tracking generator and mathematical skill (“trace maths”) enables the transmission curve of the block filter to first be swept and saved. If the transmitter output spectrum is then measured with the block filter and the block filter curve subtracted, the correct output spectrum with an increased dynamic is (theoretically) obtained.

Practice has shown that although this trick produces a sufficient dynamic to recognize out-of-band emissions, the cover of the COFDM spectrum after subtracting the two traces no longer looks nice and straight but is instead very wavy. This is due to the limited accuracy of the logarithmic amplifier in the analyser at measuring depths of 40 dB to 50 dB.

This subtraction can, of course, also be done “manually”.

In any case, correction is only important in the spectral range between f -centre $\pm 4,2$ MHz and ± 6 MHz. Near the useful signal, the dynamic of the analysers is normally sufficient and above and below f -centre ± 6 MHz, the stop filter has practically no more attenuation.

Attention when measuring the spurious emissions:

The return of the resonances from blocking filters should also be noted. In this way, block filters of the type with several $\Lambda/4$ coaxial circuits in principle also attenuate spectrums with $3 \times f$ and $5 \times f$, etc. Attention should be paid to these effects and also measured without filter if applicable at these points.

b) Attenuation curve of the block filter (see Figure E.1).

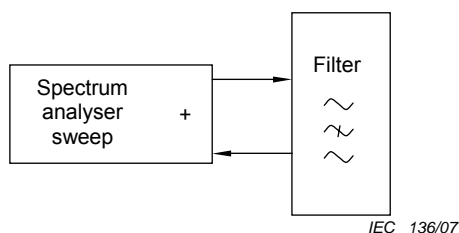

Figure E.1 – Attenuation curve

c) Out-of-band and spurious emissions with measuring block filter (see Figure E.2)

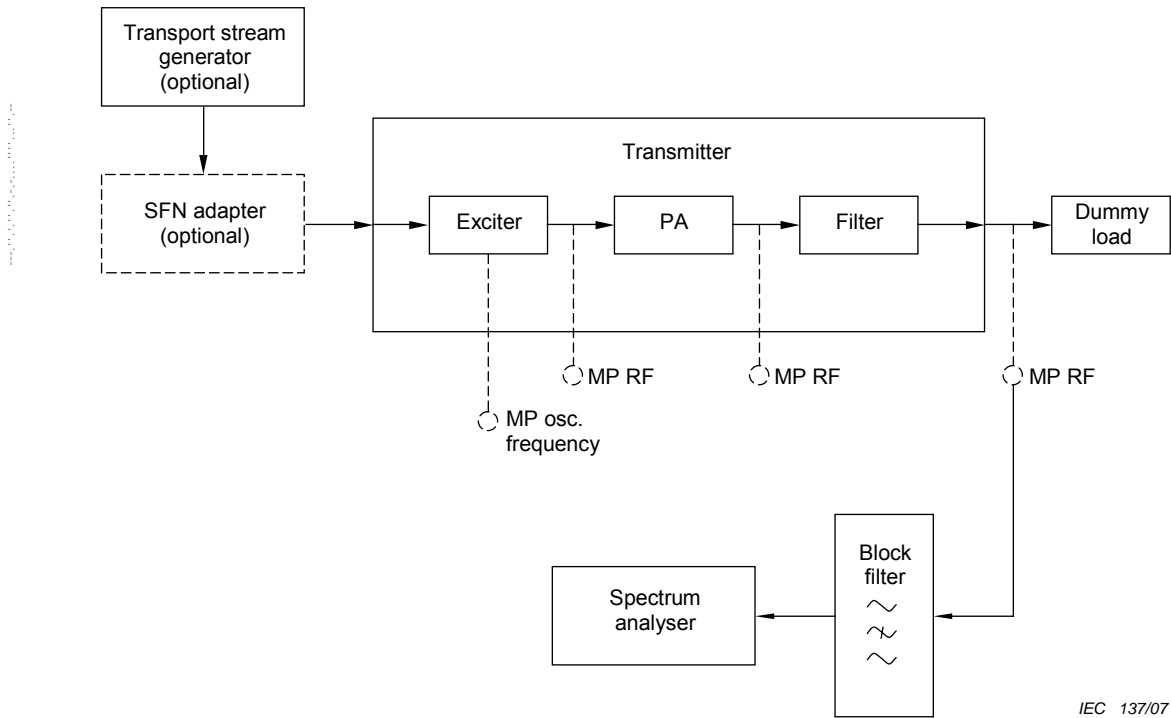

Figure E.2 – Out-of-band and spurious emissions

d) Out-of-band and spurious emissions (the filter transmission curve and the high-frequency spectrum shall be measured separately before filter).

One possibility for testing the mask for the out-of-band emissions is to carry out two measurements, but this is not possible under operating conditions!

The filter is “swept”, thereby determining the transmission curve of the filter. The r.f. output spectrum of the transmitter (without filter) is measured. Both curves are then superimposed.

e) Measuring the output filter of the transmitter (see Figure E.3)

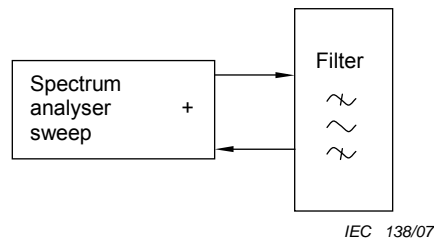
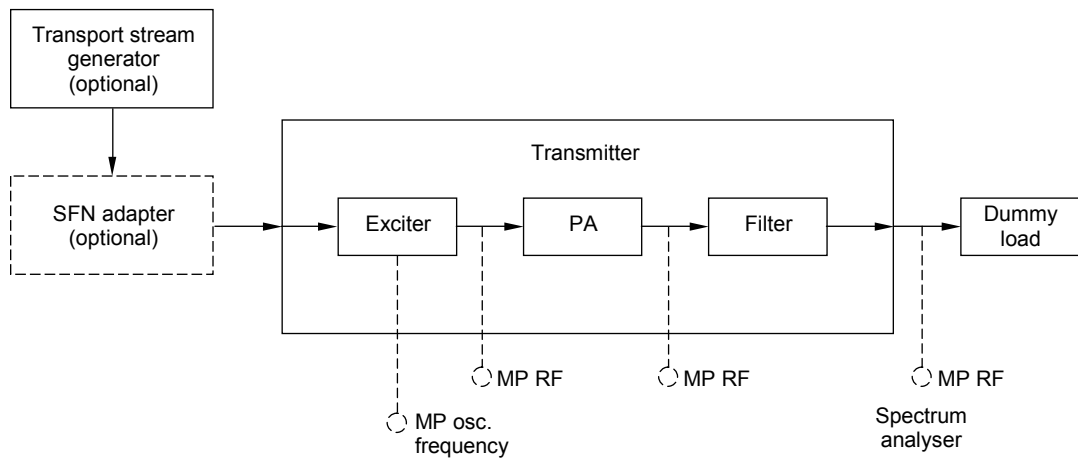

Figure E.3 – Output filter

f) Measuring the high-frequency spectrum at the transmitter without an output filter (see Figure E.4)



IEC 139/07

Figure E.4 – High-frequency spectrum

g) Superimpose curves (subtract) (see Figure E.5)

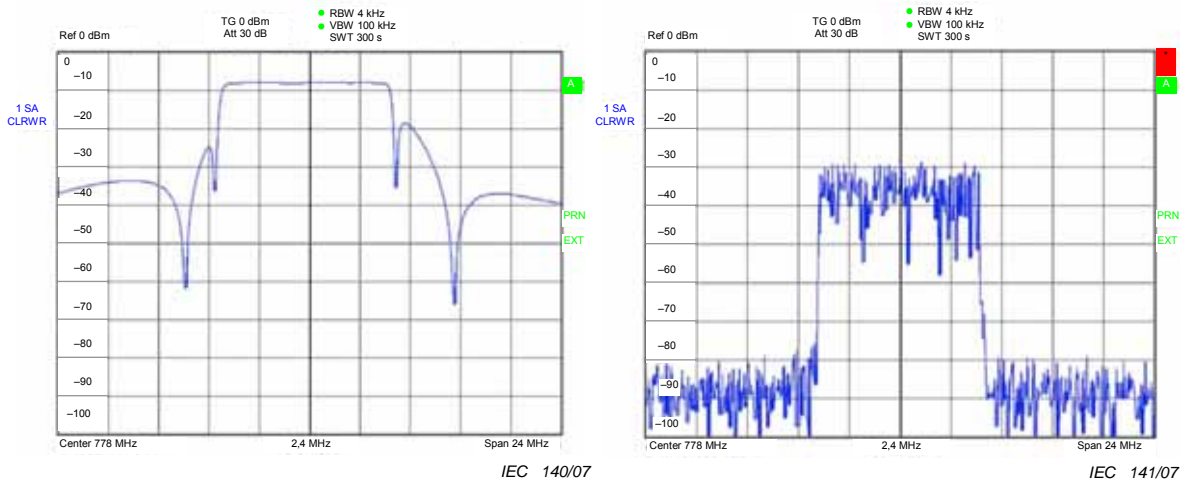

Output filter, transmission curve

RF spectrum without filter

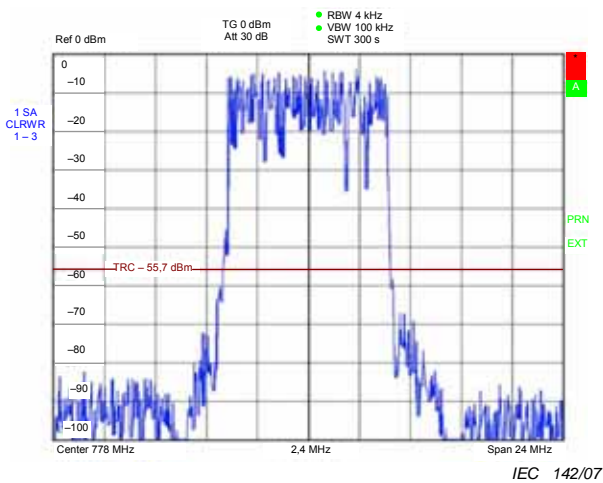

Filter and r.f. spectrum subtracted

Figure E.5 – Superimpose curve

Annex F (normative)

DVB-T shoulder attenuation measurement

F.1 Description of the test/measurement

Measuring the shoulder attenuation as defined by, for example, ETSI TR 101 290.

F.2 Measuring units

The following measuring units are required.

- Transport stream (if a PRBS mode is not available on the modulator) generator.
- SFN adapter (optional).
- Spectrum analyser with plotter connection or the possibility of exporting and printing the screen contents.

F.3 Measurement

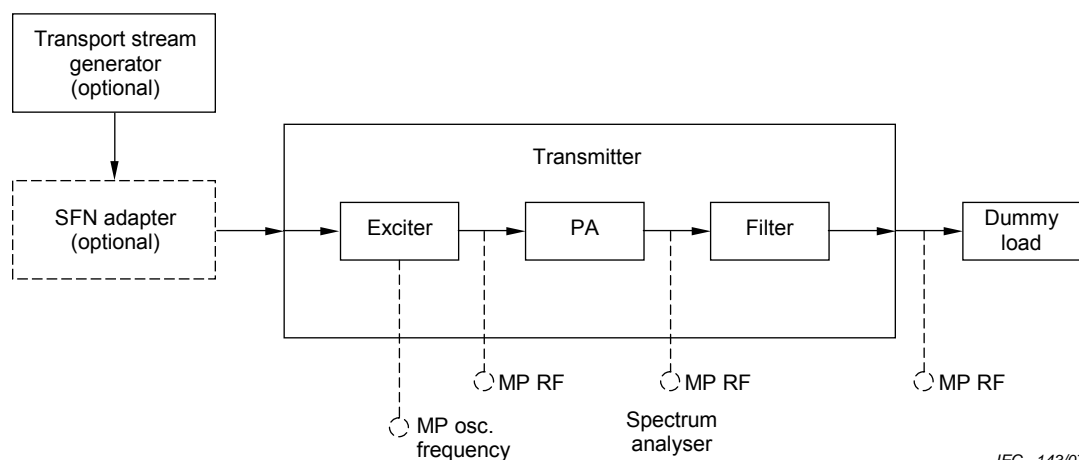

Figure F.1 – Measurement

F.3.1 Introduction

The measurement shall be carried out in 2 k and 8 k mode, various modulation parameters should be tested, and the upper and lower channel end should be measured.

The pre-correction shall be set before the measurement.

The shoulder attenuation shall be measured before the output filter. Limiting the filter always achieves a shoulder attenuation greater than the limits that are specified. Measurement behind the filter therefore results in an incorrect measurement. See Figure F.2.

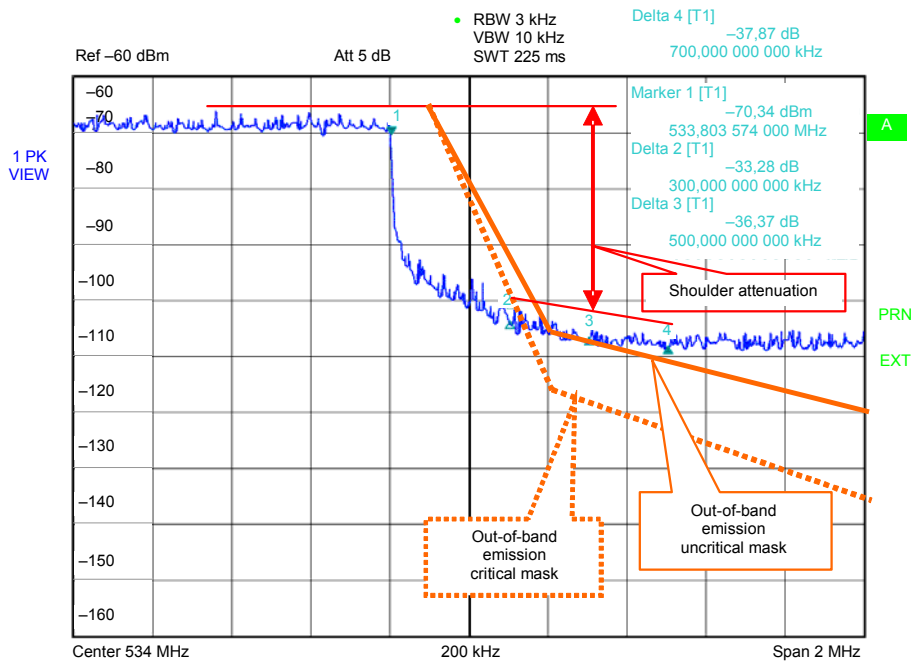

Date: 3.JUL.2002 09:32:02

IEC 144/07

Figure F.2 – Shoulder attenuation

In order to determine the shoulder attenuation exactly, a printout of the analyser image shall be made and the value determined graphically (see the red lines in Figure F.2 and F.3).

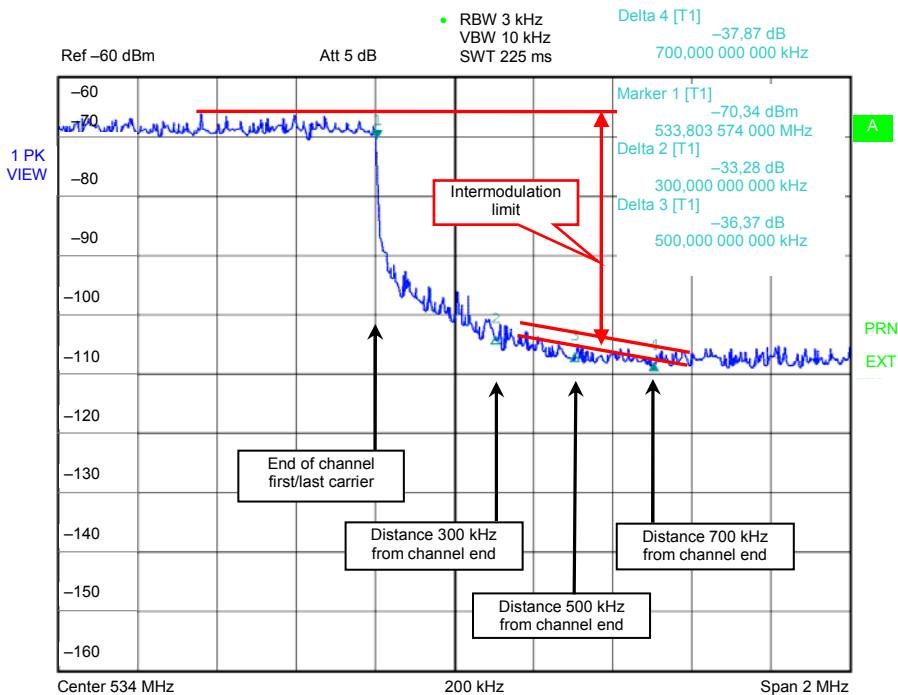

Date: 3.JUL.2002 09:32:02

IEC 145/07

Figure F.3 – Analyser setting

F.3.2 Proposal for analyser setting

The centre frequency corresponding to the channel and upper/lower band end; bandwidth 2 MHz; resolution bandwidth 10 kHz; video bandwidth 10 kHz; shall be measured for some time with "Max. hold", as the peak levels are observed (see Figure F.3).

Band start/band end in VHF (7 MHz) channel: ±3,328125 MHz from the channel centre.

Band start/band end in UHF (8 MHz) channel: ±3,803571 MHz from the channel centre.

Band start/band end in UHF (6 MHz) channel: ±2,85267857 MHz from the channel centre.

The reference is the maximum value of the OFDM spectrum, top red line.

The points shall be connected at the distance of 300 kHz and 700 kHz from the band start/band end with a line. This line shall be shifted to the maximum value in this range parallel.

The shoulder attenuation is then the level difference at 500 kHz distance from the band start/band end between the parallel-shifted line and the reference line.

The smaller (poorer) value applies if the values at the upper and lower band end are different.

F.3.3 ISDB-T shoulder attenuation

a) Measurement system

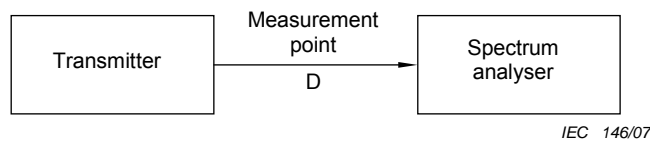

Figure F.4 – Measurement system of intermodulation

b) Measurement point

– D

c) Measuring method

- 1) A directional coupler shall be inserted into the measurement point, and then a spectrum analyser shall be connected to the directional coupler output.
- 2) The maximum level should be measured at a frequency range of 3,3 MHz to 3,5 MHz away from the centre frequency.

Intermodulation is defined as the difference between the maximum level of the OFDM signal and the maximum level measured at the specified frequency range as shown in Figure F.4. Measurement shall be made on both sides of the transmitting waves, and the larger one adopted as the measured value of intermodulation.

In the case where the transmitter deals with two or more broadcasting waves simultaneously, measurement shall be made at both frequency range of –3,3 MHz to –3,5 MHz away from the centre frequency of the lowest channel and of +3,3 MHz to +3,5 MHz away from the centre frequency of the highest channel.

- 3) The setting of the spectrum analyser shall be as follows.

Centre frequency	Span	RBW	VBW	Detect mode
Band edge frequency of the channel	4 MHz	10 kHz	300 Hz	Positive peak detection

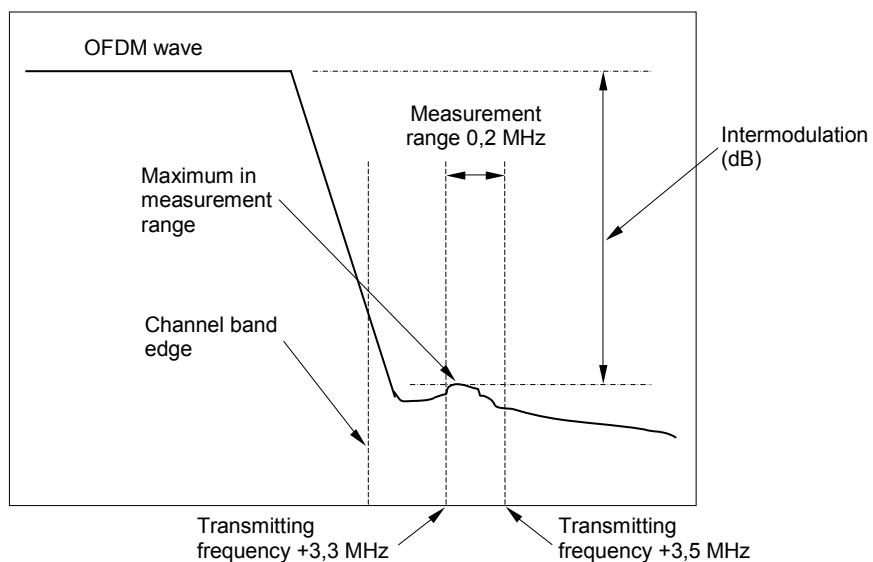

IEC 147/07

Figure F.5 – Measurement of intermodulation at the upper side of the channel

Annex G (normative)

Modulation error ratio (MER) measurement

G.1 Description of the test/measurement

The MER shows all faults displayed by the constellation diagram. For each I/Q values pair, there is a target point in the decision field of the constellation diagram. This target point is not hit exactly due to various influences in the modulator and on the transmission route. The MER now shows the deviation from the ideal state. The sum of the error vectors is compared with the sum of the ideal vectors.

The value can be given as a percentage or in decibels. An error of 1 % would correspond to 40 dB, an error of 10 % is 20 dB.

G.2 Measuring units

The following measuring units are required.

- Transport stream generator (if a PRBS mode is not available on the modulator).
- SFN adapter (optional).
- Digital measuring receiver that can show the MER via the frequency.

G.3 Measurement

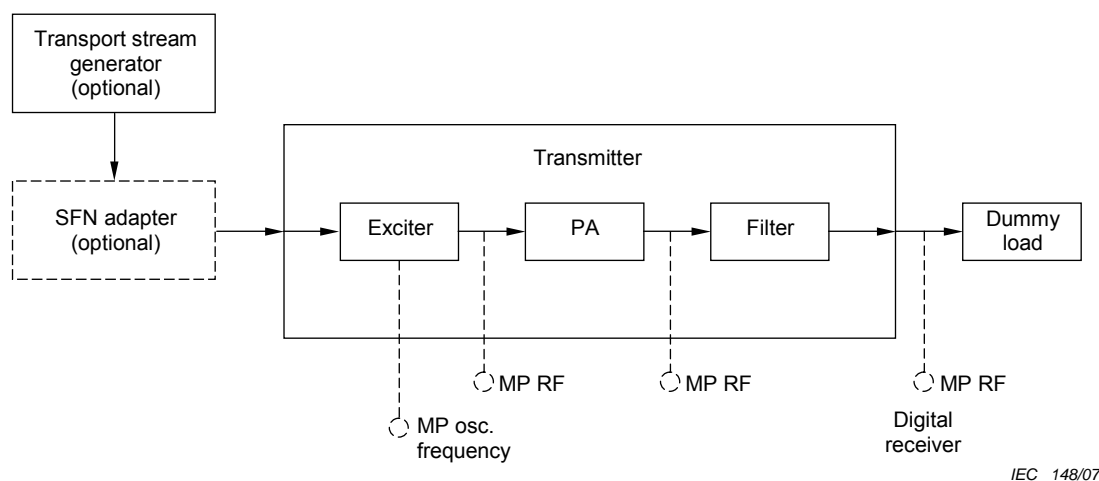

Figure G.1 – Measurement

The measuring receiver shall be connected at a measuring point after the output filter and the required frequency set. In the event of problems or in the laboratory test, the high frequency before the output filter should also be measured (see Figure G.1).

The MER shall be measured and logged via the frequency with different modulation parameters. When this is being done, the constellation diagram should be looked at and logged.

NOTE All carriers should be selected to measure the entire channel.

The result shall be a straight MER curve over the frequency without interruptions or peaks. An MER value of at least 31 dB should be reached.

Annex H (normative)

Bit error rate (BER) measurement

H.1 Description of the test/measurement

The bit error rate can be measured at three points in the digital transmission:

- directly after the demodulation without any error correction, i.e. before the “Viterbi” error correction, also designated as the raw bit error rate;
- after the first error correction, i.e. after “Viterbi” or before “Reed Solomon” (before RS);
- after the second error correction, BER after RS.

H.2 Measuring units

The following measuring units are required.

- Transport stream generator (if a PRBS mode is not available on the modulator).
- SFN adapter (optional).
- DVB-T measuring receiver that can measure the BER.

H.3 Measurement

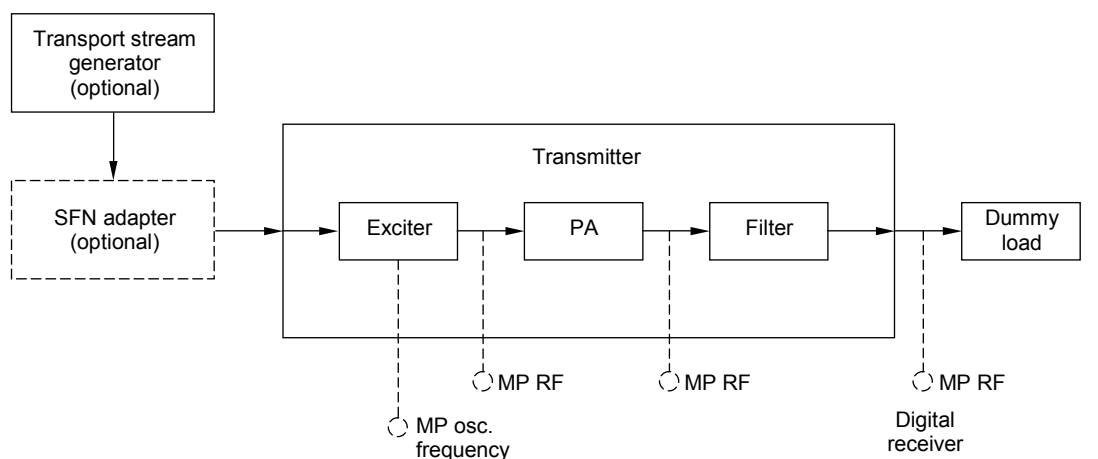

Figure H.1 – Measurement

The measuring receiver shall be connected at a measuring point after the output filter. It should be measured with various modulation parameters.

NOTE An exact statement about the BER after RS (10^{-11}) requires a longer measuring time.

Bibliography

IEC 60244-2 , *Methods of measurement for radio transmitters – Part 2: Bandwidth, out-of-band power of non-essential operations*

IEC 60244-2A, *First supplement*

JEITA Handbook, *Methods of measurement for digital terrestrial transmitter, transposer, studio to transmitter link and transmitter to transmitter link (a part of transmitter)*

www.intellectualproperty.com

ISBN 2-8318-8999-5



9 782831 889993

ICS 33.060.20

Typeset and printed by the IEC Central Office
GENEVA, SWITZERLAND